



2009 Catalog

Acorn Industrial Products Co

520 Hertzog Boulevard

King of Prussia, PA 19406

Phone 800-523-5474

Fax 800-782-6780

E-Mail acorn@acornindprod.com





TABLE OF CONTENTS

Visual Caster Guide	4	Caster Information	9-10
Accessories	5-6	Caster Mounting Application	11
Caster Application	7-8	How to Select the Right Caster	12

Caster Series

Caster Numbering System	13, 25	Twin Wheel Casters	21
9000 Series	14	Sockets	22-24
EP-RP Series	15-16	Caster Numbering System	25
EW Series	17	Wheel Selection	26
EW-EP Dual Wheel Series	18	100-500 Series	27-28
EY-EW-EP Single Wide Wheel Series	19	400-7700 Series	29-31
EY Series	20	1400-3400 Series/Stainless Steel	32-36
G400 Series	20	H1400-H3400	37-38

Wheels

Wheel Selection Guide	39-40	Cast Iron	49
RT Wheels	41-42	Sintered Iron	50
Dyna-Tred II TPR	42	Polyflex	51
Dyna-Tred TPR	43	Duraflex	52
Dyna-Tred PU	44	Pneumatic	52
Super K	45	Soft Rubber	53
K Wheel	46	Hard Rubber	54
Duro-Tred Vulcanized	47	Phenolic	55
Vulcanized Rubber Tread	48	Wheel Bearings Selection	56

Specialty Casters

Pneumatic Air Faultless Casters	57	Business Machine Casters	60
Airline Conveyor/Air Cargo	58-59	Shock Absorbing Casters	61-62



Caster
Accessories
Page 5-6



Furniture Casters
70 - 150 Lbs.
Page 14-17

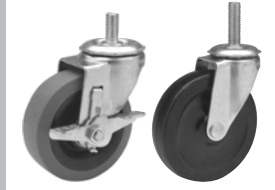

Institutional Casters
70 - 325 Lbs.
Page 18-20



Twin Wheel Casters
50 - 140 Lbs.
Page 21



Sockets &
Brackets
Page 22-24



General Duty
100/500
90 - 450 Lbs.
Page 27-28



Light-Medium Duty
400/7700
100 - 400 Lbs.
Page 29-31



Medium-Heavy
Duty/Stainless Steel
1400/3400
275 - 1,050 Lbs.
Page 32-36



Heavy Duty
H1400/H3400
420 - 1,800 Lbs.
Page 37-38



Industrial Wheel
Choices
Pages 41-55



Bearing
Selection
Page 56



Air Faultless Casters
300 - 450 Lbs.
Page 57



Airline Conveyor
Casters
270 - 375 Lbs.
Page 58-59



Low Profile Business
Machine Casters
200 - 1,200 Lbs.
Page 60



Shock Absorbing
Casters Low Profile
350 - 1,600 Lbs.
Page 61



HS/SH Industrial
Spring Action
900 - 1,200 Lbs.
Page 62

Grease Seal Kits

Grease seal holds in lubricant, reduces friction for free swiveling in contaminated environments. Field mountable.



Desc.	Order No.
Series 1400	32279
Series S1400	32293

Rollock Brake Kits

Effective gripping action across the tread keeps wheel from rolling. Field mountable. For use with Series E, 400, 1400.

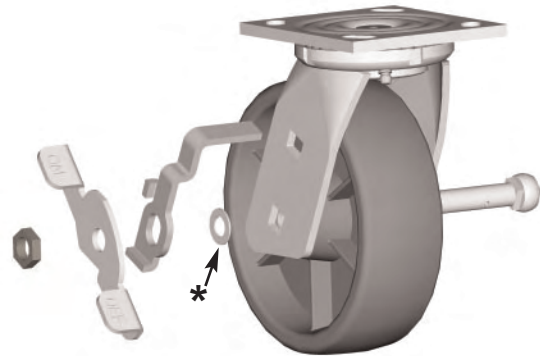

* Washer has been eliminated from use in 400 Series.

Desc.	Order No.	Stainless Order No.
20 RB Kit	32272	-
21 RB Kit	32273	-
22 RB Kit	32274	-
400-3RB Kit	32286	-
400-3½ RB Kit	32284	-
400-4 RB Kit	32275	-
400-5 RB Kit	32276	-
1400-4 RB Kit	32280	32294
1400-5 RB Kit	32277	32295
1400-6 RB Kit	32278	32296
1400-8 RB Kit	32281	32297

Side Friction Brake Kits

Cam style compression brake for use in E-Series Casters.

Desc.	Order No.
21-22 E Brake Kit	32271

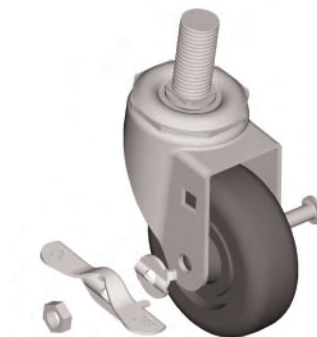

NOTE: Refer to page 29 for Rubber Expansion Sockets

Wheel Face/Total Lock Brake Kits

Series 400, 1400

Top activated brake kits for use with Series 400 or 1400. Field mountable or factory installed.



Desc.	Wheel Face Brake Order No.	Total Lock Order No.
300-3 Kit	43397	
400-3½ Kit	42672	
400-4 Kit	42673	
400-5 Kit	42674	
400-6 Kit	42675	32387
1400-4 Kit		32388
1400-5 Kit		32389
1400-6 Kit		32390
1400-8 Kit		

Cam-Style Brake Kit

Series 1400, H1400

Cam-Style compression brake for use on 1400 and H1400 Series Casters.

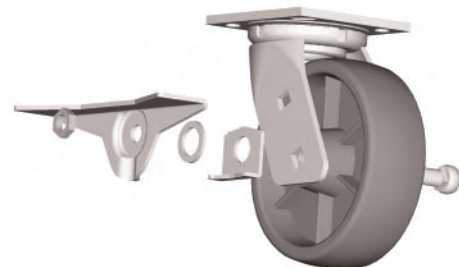

Desc.	Wheel Width	Order No.
1400, H	All Sizes	32285
H1400	2½"	32268

NOTE: 4" Cam Not Available.

Four Position Swivel Locks

Detachable four position lock instantly converts swivel casters to rigid. Field mountable.

Applies To:	Order No.
1400	46130
1400 - Foot Operated	46129
H1400	46117

NOTE: *New HX1400 Series Design Only.
 **Rigs not machined as standard.
 Consult factory for availability.

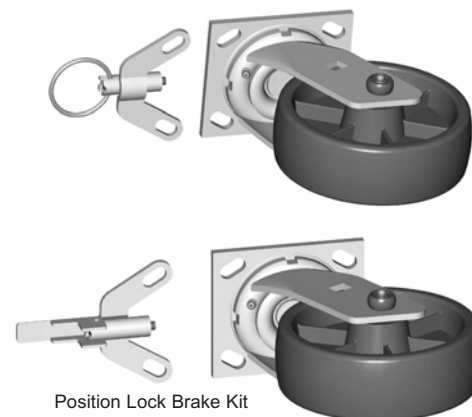

Position Lock Brake Kit

ACCESSORIES



Caster Series	Cap./Lbs	Page	Caster Series	Cap./Lbs	Page
9000 Series	70-90	17	EY Series	80-135	24
EP-RP Series	90-150	18-19	G400 Series	175-325	24
Plastic Caster Series	115-125	20	Twin Wheel	50-100	25, 26
EW Series	80-125	21	100-500 Series	90-450	32-33
EW-EP-EY Dual Whl Series	160-300	22	400-7700 Series	100-400	34-36
EK Series	115-125	23	1400-3400/Stainless Series	300-1050	39-43
K400 Series	200-300	23	H1400/3400	420-1800	44-45

Airlines

Cargo Carriers			Portable Stairways	50, 51
(Inverted Casters)	86, 87		Serving Carts	102
Dollies	40, 44		Trailers (All Purpose)	52, 54, 64
Engine Stands	52, 54, 64			

Automotive

Creepers		24	Jacks	24, 39, 50
Diagnostic Equipment	20, 34, 37-38, 84		Tire Racks	24, 34, 37
Drum Dollies	18, 24, 34		Tool Stands & Chests	24, 34, 37

Bakeries

Bowl Trucks	39, 40		Ingredient Bins	18, 19
Bread Trucks	39, 40		Platform Trucks	39, 44
Dish Trucks	38, 50		Refuse Containers	39, 44
Drum Dollies	39		Transport Dollies	39, 44

Dept./Grocery/Chain Stores/Furniture

Display Racks & Bins	17, 18, 19, 21-23, 24, 26, 32, 38-40		Office Chairs	21, 25, 26
Floor Cleaning Equipment	18, 19, 34, 37		Office Equipment Stands	17-19, 23-25
Furniture Dollies	18, 19, 32, 34		Sorting Tables	17-19, 24, 32, 38, 40
Furniture Handling Trucks	18, 19, 34, 39, 44, 50		Stock Trucks	18, 19, 24, 34, 38, 40
Garment Racks	18, 19, 21, 24		Trash Containers	39, 44, 48 50
Maintenance Trucks	34, 37, 39			

Entertainment Industry

Camera Dollies	18, 19, 21-23, 37		Packing Cases	32, 34, 37, 102, 106
Lamps	17, 18, 19, 21-23, 25, 26		Platform Trucks	34, 37, 39

Freight Terminals

Dollies		32, 34	Tool Stands & Chests	34, 37, 39, 40, 44, 56, 58, 89
Platform Trucks	38, 40, 44, 45, 56, 58, 62, 64, 93		Tow Line Trailers	39, 46, 52, 54, 60, 64
Portable Conveyors	18, 19, 21-23			

Hospital/Nursing Home/Laboratories

Beds	111-116		Lab Equipment	18, 19, 22, 34, 37, 38
Cages (animal)	37, 43		Laundry Carts	34-45
Carts (food, medicine)	16-21, 32-39		Overbed Tables	24, 25, 26
House Keeping Carts	37, 39, 84		Supply Carts	18, 19, 34, 37
Instrument Stands & Carts	18, 19, 24, 34		Trash Carts	34, 39, 50
IV Stands	24, 25, 26			



Hotel/Motel/Resorts

Audio Visual Carts	18, 19, 34	Laundry Carts	34, 37, 39, 84
Floor Cleaning Equipment	38, 42	Luggage Carts	39, 84
House Keeping Carts	34, 39, 50	Maintenance Carts	34, 37, 39

Laundries/Cleaners

Baskets	32, 34	Laundry Bins	34, 39
Garment Racks	18, 19, 24, 34		

Manufacturing Plants

Battery Racks	50, 52	Picker Carts	18, 19, 34, 37
Die & Fixture Trucks	39, 44, 50, 64	Platform Trucks	39, 44
Distribution Cages & Carts	18, 19, 34	Scaffolds	85
Drum Dollies	18, 24, 34	Tool Boxes	18, 19, 34, 38, 39, 89
Lubrication Equipment	18, 19, 24, 37	Towline or Pulled Trailers	39, 44, 50
Parts Carts	18, 19, 34, 37	Welding Machines	24, 34, 37, 39

Marine Industry

Boat Dollies	62, 64	Engine Stands	52, 54, 62, 64
Dry Dock Equipment	52, 54		

Offices/Schools/Libraries/Churches/Banks

Audio Visual Carts	18, 19, 34	Money Trucks	39, 50
Book Carts & Racks	18, 19, 34, 37, 39	Mop Buckets	21, 24, 25, 26
Chair & Table Racks	22, 32, 34, 37, 39	Office Chairs	21, 24, 25, 26
Computer/Copier Stands	24, 25, 26	Pianos	22
Floor Cleaning Equipment	38, 42	Portable Files	18, 22, 24
Janitorial Equipment	18, 19, 20, 24	Refuse Carts & Bins	34, 39
Laundry Carts	34, 37, 39, 84		

Processing Plants

Case Dollies	38-65	Platform Trucks	40-65
Curing Racks	38-65	Production Equipment	38-65
Dollies	38-65	Sausage Trucks	38-65
Heavy Trucks	40-65	Tool Boxes	38-65, 91
Ice Trucks	40-65	Towline Trucks	40-65
Mixers	40-65	Vats	40-65
Packing Stands	38-65	Waste Bins	40-65

Restaurants

Bun Racks	18, 19, 32, 34	Floor Cleaning Equipment	38, 42
Bus Carts	18, 19, 24	Milk Case Dollies	39
Chairs	21, 24, 25, 26	Portable Bars	34, 39
Dish Trucks	18, 19, 34, 37	Tool Carts	18, 19, 34, 38, 39, 89

Warehouses

Dollies	32, 34	Platform Trucks	39, 44
Pick Carts	18, 19, 34, 37	Trailers	50-65



CASTER TERMINOLOGY

CASTER INFORMATION



- 1. Overall Height** - The vertical distance between the floor and the mounting plane of the equipment.
- 2. Offset** - The horizontal distance between vertical center lines through the kingpin and the wheel center. (Not shown in diagram.)
- 3. Swivel Radius** - The horizontal distance from the vertical center line of the kingpin to the outside edge of the wheel tread. This dimension specifies the minimum distance required for the caster to swivel 360° when mounted.
- 4. Wheel Diameter**
- 5. Tread Width**

Steering - Steering is affected by the type of wheel, tread, and swivel. Swivel offset is a factor in ease of steering. Too short a lead will increase steering effort, but too much lead can reduce load capacity and may cause wobble.

Dynamic or Rolling Load - The load imposed upon a caster or wheel while in motion.

Static Load - The load imposed upon a caster while it is stationary.

Impact Load - A momentary load imposed upon a caster or wheel when a load is dropped on the equipment or it strikes an obstruction or experiences vibration.

Rollability - Rollability is the ease with which a wheel or caster can be rolled. Rollability is affected by wheel size, type of tread and bearings. The larger the wheel, the easier it will roll. A hard, narrow crowned tread rolls easier than a flat, soft tread on a smooth floor, but may be hard on floors. Soft treads protect floors and pass over floor obstructions more easily.

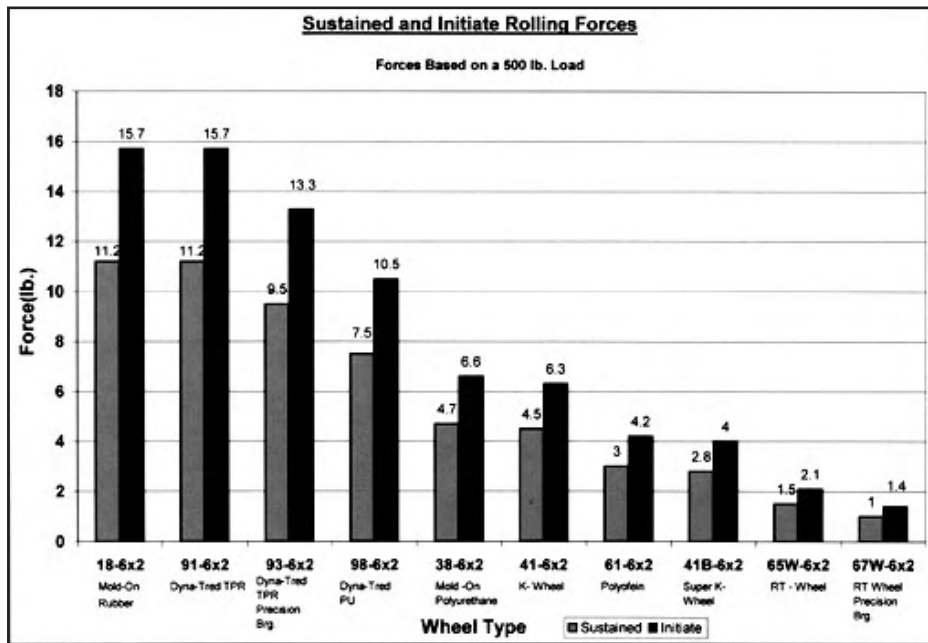

Reprinted 7/15/94 with the written permission of The Institute of Caster Manufacturers from "A Guide To Understanding And Specifying Industrial Casters And Industrial Wheels"

Top Plate - A horizontal plate for attaching a caster to equipment.

Kingpin (staked kingpin or nut & bolt assembly) - A threaded nut & bolt or staked assembly which holds the swivel assembly together. The kingpin may also be an integral part of the top plate. Threaded kingpins can be adjusted to compensate for wear in the swivel assembly.

Swivel Horn Assembly - Consists of a swivel bearing unit. It does not include wheel, wheel bearings, washers, or spanner bushing components. The spanner bushing is a non-rotating sleeve of seamless steel that fits over the axle and provides an inner raceway for wheel bearings. It strengthens the caster by allowing the legs to be tightened against it.

Rigid Horn Assembly - Consists of a rigid or stationary horn unit. It does not include the wheel, wheel bearings, washers, or spanner bushing components.

Swivel Bearings - Swivel horn assemblies may be supplied with several styles of swivel bearings. For example:

1. **Single Level Ball Race** - A single row of balls in a large diameter ball raceway. (Faultless 100 Series)
2. **Double Ball Race** - Two rows of balls moving independently through two levels of ball races. (All Faultless except 100 Series)
3. **Ball Bearing Upper Race and Tapered Roller Thrust** - A single row of balls in the upper race coupled with a precision tapered roller bearing in the lower race.
4. **Precision Upper Race and Lower Race Bearings** - A self-contained precision load bearing for the upper race coupled with a precision tapered roller bearing in the lower race.

Caster Assembly Breakdown

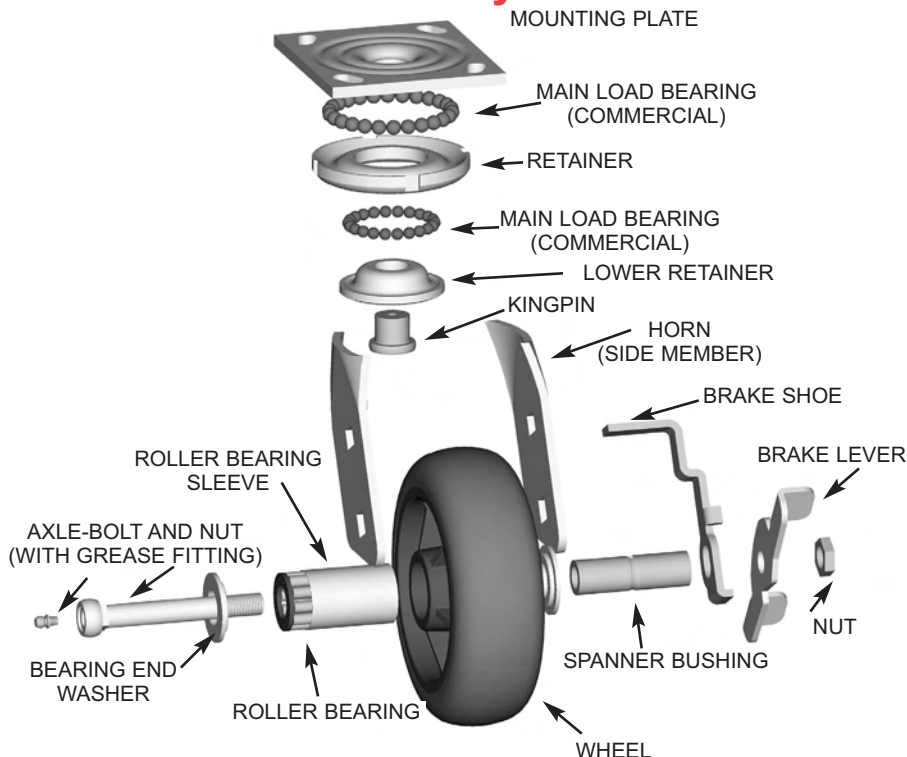

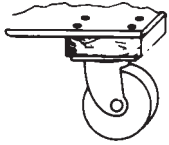

Swivel plate bolts or welds to cross support and floor truck.

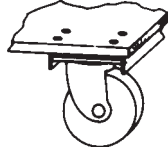

Swivel plate bolts to wood to inverted channel iron cross support and floor truck.

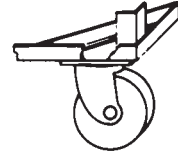

Swivel plate bolts or welds to angle iron frame and corner brace.

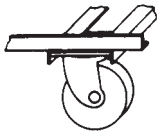

Swivel plate bolts or welds to angle iron frame and inverted cross supports.



Swivel plate bolts or welds to U-beams used as cross supports.

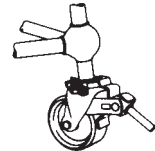

Stem caster with combination swivel and wheel brake protects workmen on scaffolds.

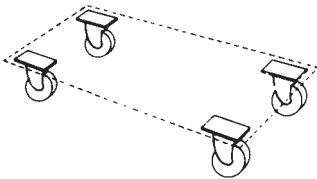

Four swivel casters respond instantly to directional change, making parking easy in limited space. Recommended for short distances, crowded conditions.

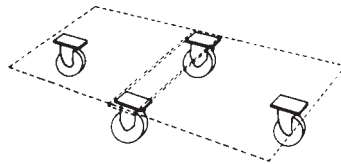

Two rigid casters at sides, two swivel casters at ends make a highly maneuverable truck that turns in its own length.

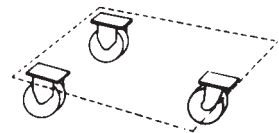

Two rigid, one swivel caster make a maneuverable triangle dolly for light loads.

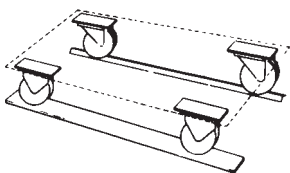

Two V-grooved casters on angle-iron track and two plain rigid casters rolling on metal plate make an ideal production line carrier.

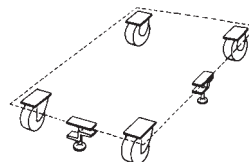

Two swivel and rigid casters provide easy steering over long distances. Floor truck lock holds securely for loading or unloading, sets and releases with a simple step-down.

When Specifying or Replacing Casters, Answer These Seven Important Questions:

1. What is the average load and the maximum load?
2. What wheel type is needed for floor protection?
3. What wheel diameter will give the necessary mobility?
4. In what type of environment will the casters or wheels operate (water, oils, acids, corrosive materials, or excessive temperatures)?
5. Will the unit be hand-pushed or powered?
6. How many swivel and how many rigid casters are needed?
7. How are the casters to be mounted? i.e. Top Plate, Stem, Hollow Kingpin, etc.

Load + weight of truck ÷ number of casters = lbs. per caster
For example: 2000 lbs. ÷ 4 casters = 500 lbs. per caster



Divide combined weight of load and truck to get weight-per-caster.
Faultless load ratings include a substantial safety factor. If a load is dropped onto a truck without regard for breakage, then specify the next higher load rating. Generally, select casters with extra load capacity rather than “just enough to get the job done.”



CASTER NUMBERING SYSTEM

Institutional/Furniture Casters

E	W	9	5	11	R	TG
Series	Mounting Options	Wheel Material*	Finish	Size	Suffix	Suffix

E - Double Ball Bearing (wide variety of mountings)	W - Wide Friction Band - Short (7/16" x 1-3/8")	1 - Dyna-Tred II TPR (Gray Thermoplastic Tread)	1 - Antique	8 - 1-5/8"	R - Riveted Axle	TG - Thread Guard
9000 - Double Ball Bearing (light duty plate mounting)	R - Wide Friction Band - Long (7/16" x 2-1/32")	3 - Plastic	2 - Black Oxidized	9 - 2"	M - White Wheel	B&N - Bolt & Nut
IT - Twin Wheel Casters (Twin Wheel Mounting Options include H, W, Y, and P)	K - Institutional Stem (multiple sizes available)	4 - Rubber	3 - Nickel	11 - 2-1/2"	W - Black Wheel	B - Brake (Twin Wheels)
R - Rigid Caster	Y - Threaded Stem	6 - Polypropylene	4 - Brass	20 - 3"		TB - Total Brake
	P - Plate (multiple sizes available)	7 - Hard Rubber	5 - Zinc	21 - 4"		SB - Side Brake
		9 - Dyna-Tred II PU		22 - 5"		RB - Rollock Brake



EW9511RTG



Series 9000 Plate Casters

Load Capacity 70-90 Lbs. Each Caster



Double ball bearing swivel makes this a quality plate caster for flat-base furniture such as chests, cabinets, and lighter school and hospital equipment.

Wheel Dia. (In.)	Tread Width (In.)	Wheel Material	Load Rating (Lbs.)	Overall Height (In.)	Finish	Caster Desc.	Order No.
1 5/8	47/64	Soft Rubber	70	2 9/32	Zinc	9458R	28472
2	7/8	Soft Rubber	80	2 5/8	Zinc	9459BR	28474
		Dyna-Tred II TPR	80	2 5/8	Zinc	9159R	28470
3	1 3/16	Soft Rubber	90	3 19/32	Zinc	94520R	28486
		Dyna-Tred II TPR	90	3 19/32	Zinc	91520R	28488

Hard Rubber or Polypropylene wheels available on 2" and 3" sizes

Mounting Bolt Diameter — 3/16"

3" wheel has a top plate size of 2 1/8" x 1 1/8" and like mounting hole spacing

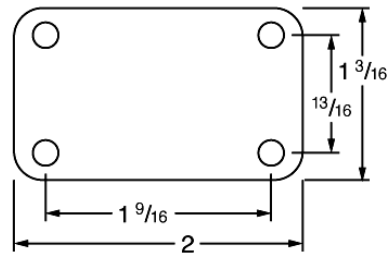

CASTERS



Series EP-RP

Load Capacity 90-150 Lbs. Each Caster

Recommended for light assembly dollies and trucks, bakery racks, portable files, tool boxes, display racks, and many other uses.

CASTERS

- **TB** — Dual brake available on 5" diameter caster. Locking of wheel and swivel for extra safety and stability
- **Swivel Casters** — Full-drawn horn provides both upper and lower raceways. Deep-drawn, corrugated top plate also forms main load raceway
- **Load Bearing** — Two full, independent rows of hardened ball bearings roll in separate raceways for superior swiveling
- **Kingpin** — Fully annealed kingpin holds raceways precisely in alignment
- **Wheel Bearings** — Self-lubricating and plain bearings are available
- **Finish** — Corrosion-resistant zinc

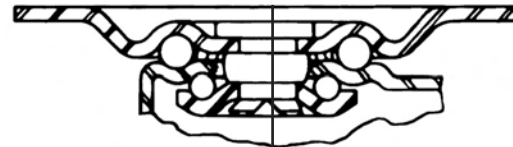

NOTE: Double Ball Raceway

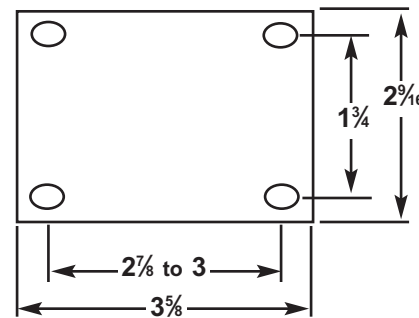

Wheel Options



Soft Rubber



Hard Rubber



Polypropylene



Dyna-Tred II
TPR

Series EP- RP

Load Capacity 90-150 Lbs. Each Caster



Wheel Dia. (In.)	Tread Width (In.)	Wheel Material	Wheel Bearing	Load Rating (Lbs.)	Swivel Caster Desc.	Order No.	Rigid Caster Desc.	Order No.
3	1 ³ / ₁₆	Soft Rubber	Plain	90	EP4520	29906	RP4520	31232
		Soft Rubber	Plain	90	EP4520RB	29909	-	-
		Polypropylene	Plain	110	EP6520	29814	RP6520	25126
		Hard Rubber	Plain	100	EP7520	29922	RP7520	31249
		Hard Rubber	Plain	100	EP7520SB	29936	-	-
		Dyna-Tred II TPR	Plain	90	EP1520	29821	RP1520	31221
4	1 ⁵ / ₁₆	Soft Rubber	Plain	115	EP4521	29918	RP4521	31239
		Soft Rubber	Plain	115	EP4521RB	29920	-	-
		Polypropylene	Plain	140	EP6521	29815	RP6521	25133
		Hard Rubber	Plain	140	EP7521	29955	RP7521	31260
		Hard Rubber	Plain	140	EP7521SB	29956	-	-
		Dyna-Tred II TPR	Plain	115	EP1521	29823	RP1521	31223
5	1 ⁵ / ₁₆	Soft Rubber	Plain	125	EP4522	29933	RP4522	31247
		Soft Rubber	Plain	125	EP4522RB	29935	-	-
		Polypropylene	Plain	150	EP6522	29831	RP6522	25138
		Hard Rubber	Plain	150	EP7522	29952	-	-
		Dyna-Tred II TPR	Plain	125	EP1522	29825	RP1522	31225
		Dyna-Tred II TPR	Plain	125	EP1522TB*	29817	-	-

Wheel Diameter (A)	3"	4"	5"
Overall Height (B)	3 ³ / ₄ "	4 ¹³ / ₁₆ "	5 ¹³ / ₁₆ "
Swivel Radius (C)	2 ³ / ₄ "	3 ⁵ / ₁₆ "	3 ¹⁵ / ₁₆ "
Axle Size	1/4"	5/16"	5/16"

OPTIONS:

1. RB for Rollock Brake
2. SB for Side Brake
3. TG for Thread Guard
4. TB for Total Lock Brake — 5" only
5. B & N — Bolt & Nut Axle standard
6. R — Riveted axle optional

*Total Lock Brake overall height is 6¹/₂"

Mounting Bolt Diameter — 5/16"

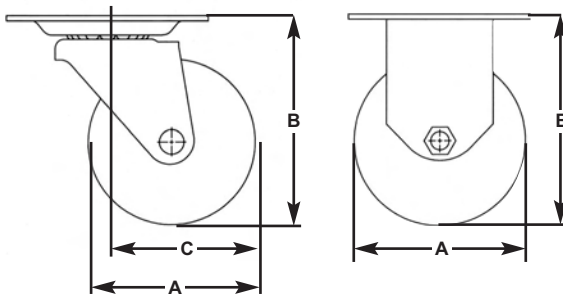

CASTERS

Options



Total Lock Brake



Side Brake



Rollock Brake



Thread Guards



FURNITURE CASTERS

Series EW Stem Casters

Load Capacity 80-125 Lbs. Each Caster



Double ball bearing construction assures easy swiveling for heavy furniture, appliances, equipment, or point-of-purchase displays. Friction-grip stem can fit directly into cast aluminum, molded plastic, or pressed-steel chair bases. Also used with EW brackets for angle-iron legs and steel, plastic, and RT sockets for tubular metal legs.

Wheel Dia. (In.)	Tread Width (In.)	Wheel Material	Load Rating (Lbs.)	Overall Height (In.)	Finish	Swivel Caster Desc.	Order No.
2	7/8	Soft Rubber	80	2 17/32	Nickel	EW439BR*	30247
		Soft Rubber	80	2 17/32	Zinc	EW459BR*	30301
	3/4	Dyna-Tred II TPR	80	2 17/32	Zinc	EW159R*	30159
2 1/2	1 3/16	Soft Rubber	80	3 1/32	Zinc	EW4511R*	30180
		Soft Rubber	80	3 1/32	Nickel	EW4311R*	30191
		Dyna-Tred II TPR	80	3 1/32	Zinc	EW1511R*	30186
3	1 3/16	Soft Rubber	90	3 1/2	Nickel	EW4320*	30317
		Soft Rubber	90	3 1/2	Zinc	EW4520*	30333
		Dyna-Tred II TPR	90	3 1/2	Zinc	EW1520*	30324
4	1 5/16	Soft Rubber	115	4 5/8	Nickel	EW4321**	30372
		Soft Rubber	115	4 5/8	Zinc	EW4521B&N**	30345
		Dyna-Tred II TPR	115	4 5/8	Zinc	EW1521B&N**	30392
5	1 5/16	Soft Rubber	125	5 5/8	Zinc	EW4522**	30357
		Dyna-Tred II TPR	125	5 5/8	Zinc	EW1522**	30201

CASTERS

*Standard Stem: 7/16" diameter, 1 3/8" long (Specify 5567-6)

**Standard Stem: 7/16" diameter, 1 17/32" long (Specify 5567-4)

Alternate Stem: 7/16" diameter, 1" long (Specify 5567-1)

See page 28-29 for EW Sockets

Hard Rubber and Polypropylene wheels available

Friction Brake available (Suffix SB) (2", 2 1/2", 3", 4", 5")

Rollock Brake available (Suffix RB) (3", 4", 5")

Bore dimensions: 29/64" dia., 1/16" depth.

Stem can be used with EW tube sockets or brackets.

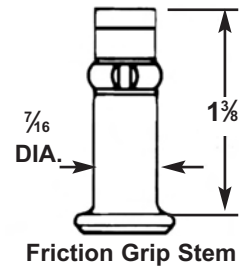

Series EW-EP Dual Wheel Casters

Load Capacity 160-275 Lbs. Each Caster

Ideal for pianos and equipment. Combines high load capacity with excellent mobility and floor protection. Full double ball bearing construction provides easy swiveling and long service life.



CASTERS

Wheel Diameter (In.)	Tread Width (In.)	Wheel Material	Load Rating (Lbs.)	Overall Height (In.)	Finish	Caster Desc.	Order No.
2	7/8	Soft Rubber	160	2 ²³ / ₃₂	Copper Oxide	EW479-2*	30373
		Soft Rubber	160	2 ²⁷ / ₃₂	Copper Oxide	EP479-2**	29941
		Hard Rubber	275	2 ²⁷ / ₃₂	Zinc	EP759-2**	29960
		Hard Rubber	275	2 ²³ / ₃₂	Zinc	EW759-2*	30475

Friction Grip Stem: 7/16 x 1-17/32

Bore dimensions: 29/64" dia., 1-9/16" depth. Stem can be used with EW tube sockets or brackets.

*Use with W98 Socket

**Top Plate: 2-9/16" x 3-5/8"

Bolt Holes: 1-3/4" x 2-7/8" to 3"

NOTE: Side Brake Available.

Series EY-EW-EP Single Wide Wheel Casters

Load Capacity 220-300 Lbs. Each Caster

Ideal for point of purchases displays and low profile computer equipment. These casters combine high load capacity with excellent mobility and floor protection. Full double ball bearing construction provides easy swiveling and long service life.



Wheel Diameter (In.)	Tread Width (In.)	Wheel Material	Load Rating (Lbs.)	Overall Height (In.)	Finish	Caster Desc.	Order No.
1 ⁵ / ₈	1 ¹¹ / ₁₆	Polypropylene	220	2 ⁷ / ₃₂	Zinc	HXEP658R*	31157
		Polypropylene	220	2 ¹ / ₈	Zinc	HXEY658R**	25836
2	1 ¹¹ / ₁₆	Polypropylene	300	2 ²⁷ / ₃₂	Zinc	HXEP659R*	31154
		Polypropylene	300	2 ³ / ₄	Zinc	HXEY659R**	25843
		Polypropylene	300	2 ³ / ₄	Zinc	HXEW659R***	31149

*Top Plate: 2-⁹/₁₆" x 3-⁵/₈" Bolt Hole: 1-³/₄" x 2-¹⁵/₁₆"; **Thread Stem: ¹/₂" x 13 x 1-¹/₂";

***Friction Grip Sem: ⁷/₁₆" x 1-¹⁷/₃₂".

Contact factory for brake options.

Piano Sockets

For EW Series Dual Wheel Piano Casters. Socket bore ⁹/₁₆" x 1¹/₂" depth. 2¹/₈" diameter trackplate.



Socket No.	EDP No.
W98	38353



Series EY Casters

Load Capacity 80-135 Lbs. Each Caster

Double ball bearing design makes the easy-swiveling Series EY ideal for metal furniture, carts, racks, appliances and more. Machine-threaded stems are available in made-to-order custom sizes.



Wheel Dia. (In.)	Tread Width (In.)	Wheel Material	Wheel Bearing	Axle Size (In.)	Load Rating (Lbs.)	Overall Height (In.)	Swivel Caster Desc.	Order No.
2	7/8	Soft Rubber	Plain	1/4	80	2 17/32	EY459R*	30648
	3/4	Dyna-Tred II TPR	Plain	1/4	80	2 17/32	EY159R*	30539
3	1 3/16	Soft Rubber	Plain	1/4	90	3 1/2	EY4520*	30719
		Dyna-Tred II TPR	Plain	1/4	90	3 1/2	EY1520*	30738
4	1 5/16	Soft Rubber	Plain	5/16	115	4 1/16	EY4521**	30764
		Hard Rubber	Plain	5/16	125	4 1/16	EY7521**	30843
		Dyna-Tred II TPR	Plain	5/16	115	4 1/16	EY1521**	30771
5	1 5/16	Soft Rubber	Plain	5/16	125	5 23/32	EY4522**	30797
		Hard Rubber	Plain	5/16	135	5 23/32	EY7522**	30842
		Dyna-Tred II TPR	Plain	5/16	125	5 23/32	EY1522**	30807

Note: R — Riveted Axle Brake Options available on most items. *Stem Size 3/8 - 16x1 1/2" **Stem Size 1/2 - 13x1 1/2" Hard Rubber and Polypropylene wheels available.

Series G400 (Threaded Stem Casters)

Load Capacity 175-325 Lbs. Each Caster

This Faultless caster offers the smooth, quiet swiveling made possible by double ball bearing construction. Threaded stem attaches to wire grocery trucks, brackets, plugs, legs, etc. Corrosion-resistant zinc finish.



Wheel Dia. (In.)	Tread Width (In.)	Wheel Material	Wheel Bearing	Axle Size (In.)	Load Rating (Lbs.)	Overall Height (In.)	Swivel Caster Desc.	Order No.
3	1 1/4	Soft Rubber	Plain	3/8	175	3 3/4	G421-3	25565
		Soft Rubber	Plain	3/8	200	4 7/8	G421-4	25590
4	1 1/4	Soft Rubber	Plain	3/8	200	4 7/8	G421-4RB	25478
		Dyna-Tred TPR	Delrin	3/8	225	4 7/8	G490-4	24980
		Dyna-Tred TPR	Delrin	3/8	225	4 7/8	G490-4RB	24981
		Dyna-Tred TPR	Precision	3/8	225	4 7/8	G493-4TG	25200
		Dyna-Tred TPR	Precision	3/8	225	4 7/8	G493-4RBTG	25201
		Dyna-Tred PU	Precision	3/8	275	4 7/8	G499-4TG	24927
		Dyna-Tred PU	Precision	3/8	275	4 7/8	G499-4RBTG	24928
		RT Wheel	Delrin	3/8	300	4 7/8	G464W-4	24892
	1 1/2	RT Wheel	Delrin	3/8	300	4 7/8	G464W-4RB	24893
		RT Wheel	Roller	3/8	300	4 7/8	G465W-4	24895
RT Wheel		Roller	3/8	300	4 7/8	G465W-4RB	24896	
5		1 1/4	Soft Rubber	Plain	3/8	200	6	G421-5
	Soft Rubber		Plain	3/8	200	6	G421-5RB	25560
	Dyna-Tred TPR		Delrin	3/8	250	6	G490-5	24982
	Dyna-Tred TPR		Delrin	3/8	250	6	G490-5RB	24983
	Dyna-Tred TPR		Precision	3/8	250	6	G493-5TG	26012
	Dyna-Tred TPR		Precision	3/8	250	6	G493-5RBTG	26013
	Dyna-Tred PU		Precision	3/8	300	6	G499-5TG	25202
	Dyna-Tred PU		Precision	3/8	300	6	G499-5RBTG	25203
	1 1/2	RT Wheel	Delrin	3/8	325	6	G464W-5	24898
		RT Wheel	Delrin	3/8	325	6	G464W-5RB	24899
RT Wheel		Roller	3/8	325	6	G465W-5	24901	
RT Wheel		Roller	3/8	325	6	G465W-5RB	24902	

Stem Dimensions: 1/2 - 13x1 1/2" standard. Other stem dimensions available. High Temperature version available. Contact factory. (RB- Rollock Brake) (WFB - Wheel Face Brake)



Twin Wheel Casters

Load Capacity 50-100 Lbs. Each Caster

Nylon hooded caster offers designer styling combined with economy. Independent wheel rotation adds to its already high controlled mobility from deep pile carpeting to slick tile. Meets or exceeds BIFMA Standards.



A



B



C



D

CASTERS

Dia. (mm)	Load Rating (Lbs.)	Overall Height (In.)	Horn Finish	Caster Desc.	Order No.
Stem Caster for Wood Furniture (A)					
40	50	2 ⁵ / ₃₂	Black	IT332HN-40	48104
50	90	2 ¹ / ₂	Black	IT332HN-50	48425
50	90	2 ¹ / ₂	Brass	IT334HN-50	48046
50	90	2 ¹ / ₂	Antique	IT331HN-50	48421
50	90	2 ¹ / ₂	Chrome	IT33SSH-50	48050
Friction Grip Stem (B)					
50	90	2 ¹ / ₂	Black	ITW32HN-50	46180
50	90	2 ¹ / ₂	Brass	ITW34HN-50	48044
50	90	2 ¹ / ₂	Chrome	ITW3SSH-50	46044
60	100	2 ³ / ₄	Black	ITW32HN-60	45450
60	100	2 ³ / ₄	Chrome	ITW3SSH-60	45457
Standard Top Plate (C)					
40	50	2 ⁷ / ₃₂	Black	IT932HN-40	48106
50	90	2 ¹¹ / ₁₆	Black	IT932HN-50	48039
50	90	2 ¹¹ / ₁₆	Brass	IT934HN-50	48041
50	90	2 ¹¹ / ₁₆	Chrome	IT93SSH-50	48043
60	100	2 ⁹ / ₁₆	Black	IT932HN-60	48414
38mm Barrel, Friction Grip Stem (D)					
50	90	2 ¹ / ₂	Black	ITW32EHN-50	46260

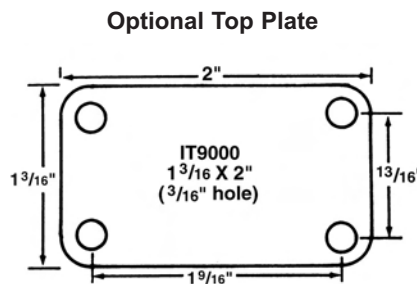
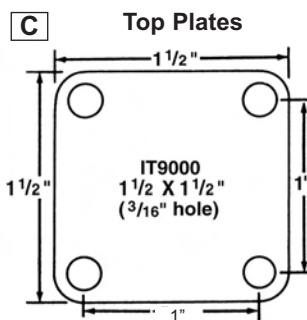
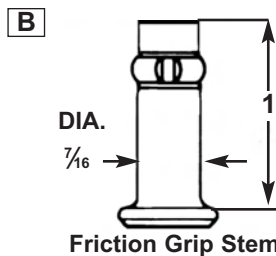
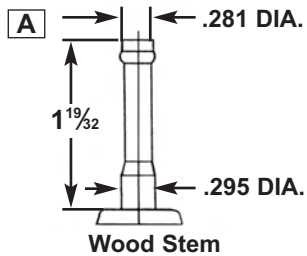



Spring Steel Grip Neck Sleeve

Designed for wood applications, these steel sockets hold grip neck stem casters securely.

Hole Diameter (In.)	Depth (In.)	Description	Caster Series	Socket Desc.	Order No.
$\frac{3}{8}$	$1\frac{5}{8}$	$\frac{3}{4}$ " Toothed Trackplate	Wood Stem	505GN	38372

Pipe-Thread Socket

Use with EW stem caster.



Dia. (In.)	Base (In.)	Socket Desc.	Order No.
$\frac{3}{4}$	1	W44	39549

Steel Brackets for EW Series Casters

Bolted on or welded, Faultless steel brackets adapt EW Series casters to a wide variety of channel or angle-iron legs.



Order No. 39555

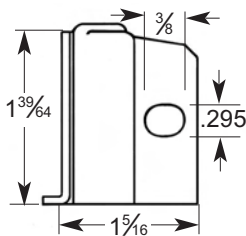

No. 49 Bolted For Inside Angle Iron



Order No. 39554

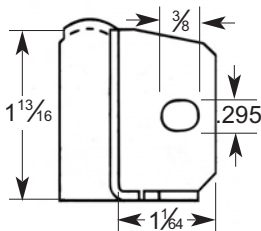

No. 48 Bolted For Outside Angle Iron

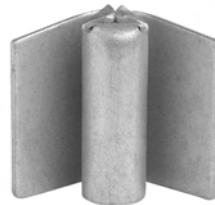

Order No. 42264

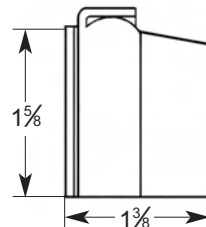

No. 52 Welded For Inside Angle Iron



Order No. 39568

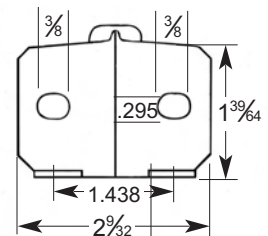

No. 81 Flat Bracket

SOCKETS

Round Tubular



RT

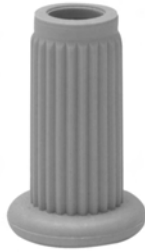

P120

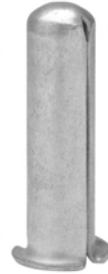

53



54

SOCKETS

Gage	Tube		Caster Series	Minimum Hole		Material	Socket Desc.	Order No.
	ID (In.)	OD (In.)		Depth (In.)				
17	0.571	0.6875	ER	2.25		Steel	53R	42248
17	0.571	0.687	EW	2.25		Steel	54	38393
11	0.578	0.687	X, EX	1.625		P/E	X701	43481
16	0.62	0.75	EW	2.25		Steel	79	39564
18	0.777	0.875	ER, EW	1.812		P/E	P120	43441
18	0.777	0.875	ER, EW	2.125		RT	RT120RD	43400
13	.872	1.062	ER, EW	1.25		P/E	P123	43446
12	0.844	1.062	ER, EW	1.25		P/E	P124	43447
13	0.872	1.062	ER, EW	2.125		RT	RT123RD	43401
18	0.902	1	ER, EW	1.812		P/E	P125	43486
18	0.902	1	ER, EW	2.125		RT	RT125RD	43403
11	1.072	1.312	ER, EW	2.125		RT	RT126RD	43404
16	1.12	1.25	ER, EW	2.125		RT	RT127RD	43405
13	1.31	1.5	ER, EW	2.125		RT	RT1310RD	43515
16	1.37	1.5	ER, EW	2.125		RT	RT1370RD	43409
16	1.495	1.625	ER, EW	2.125		RT	RT1495RD	43520

P/E — Polyethylene
P/P — Polypropylene
RT — Reinforced Thermoplastic

Square Tubular



RT



EW4689

Gage	Tube		Caster Series	Minimum Hole	Material	Socket Desc.	Order No.
	ID (In.)	OD (In.)		Depth (In.)			
16	0.62	0.75	ER, EW	2.125	RT	RT620SQ	43531
18	0.652	0.75	ER, EW	2.125	RT	RT650SQ	43530
16	0.87	1	EW	1.312	P/E	EW4689SQ	43484
.080 Wall	0.88	1.04	ER, EW	2.125	RT	RT880SQ	43507
18	0.902	1	ER, EW	2.125	RT	RT902SQ	42254
18	0.902	1	ER	1.875	P/E	ER4983SQ	43491
11	1.01	1.25	ER, EW	2.125	RT	RT1010SQ	43516
16	1.12	1.25	ER, EW	2.125	RT	RT1120SQ	43517
18	1.152	1.25	ER, EW	2.125	RT	RT1150BSQ	43522
18	1.152	1.25	ER, EW	2.125	RT	RT1150SQ	43521
7	1.14	1.5	ER, EW	2.125	RT	RT1140SQ	43518
18	1.402	1.5	ER, EW	2.125	RT	RT1400SQ	43519

P/E — Polyethylene

RT — Reinforced Thermoplastic

- Faultless plastic sockets are designed to retain casters in a wide variety of wood and metal furniture, appliances, and equipment.
- Sockets absorb side thrust shocks, deaden noise, and will not rust.
- Metal sockets and brackets are zinc plated to resist rust.
- R.T. sockets are constructed of reinforced thermoplastic which is virtually indestructible with EW and ER Series Swivel Casters.

Rubber Expansion



Socket Desc.	Order No.	Fits Round Tube Size	I.D. Tube Size (In.)	Fits Stem Size (In.)
RX1000	41482	1" - 16 GA	.870 - 1.0	1/2 - 13 x 2 1/8 - 2 1/4
RX1250	41483	1 1/4" - 16 GA	1.120 - 1.25	1/2 - 13 x 2 1/8 - 2 1/4
RX1500	41484	1 1/2" - 16 GA	1.375 - 1.5	1/2 - 13 x 2 1/8 - 2 1/4
RX1620	41485	1 5/8" - 16 GA	1.495 - 1.625	1/2 - 13 x 2 1/8 - 2 1/4

Socket Desc.	Order No.	Fits Square Tube Size	I.D. Tube Size (In.)	Fits Stem Size (In.)
SX1000	41486	1" - 16 GA	.870 - 1.0	1/2 - 13 x 2 1/8 - 2 1/4
SX1250	41487	1 1/4" - 16 GA	1.120 - 1.25	1/2 - 13 x 2 1/8 - 2 1/4
SX1500	41488	1 1/2" - 16 GA	1.375 - 1.5	1/2 - 13 x 2 1/8 - 2 1/4
SX1620	41489	1 5/8" - 16 GA	1.495 - 1.625	1/2 - 13 x 2 1/8 - 2 1/4

Note: Expansion Sockets to be used with 1/2 - 13 threaded stem casters.



Industrial Duty

Caster Numbering System

Faultless manufactures industrial casters in many types, sizes, and styles — some 10,000 different items in all. To identify them, we've developed an alpha-numerical Industrial Caster Numbering System. The illustration breaks down one caster number into its component parts, so you can see how it works. The chart lists other letters and numbers, and what each one means.

HX	14	41B	8	TSB
Prefix Letter	Rigid or Swivel Construction	Kind of Wheel and Bearing	Wheel Diameter	Suffix Options
A — Special Top Plate Size	1 — Swivel	06 — Semi-Steel — Roller Bearing	2	B — Variation from standard wheel
	5 — Rigid	07 — Forged Steel Wheel — Tapered Bearing	2½	
C — Swivel Stem Caster with Brake	3 — Swivel	08 — Powdered Iron — Plain Bore	3	BM — Black Oxide Finish
	97 — Rigid	16 — Mold-on Rubber Balloon — Ball Bearing	3½	
D — Special Top Plate Size	4 — Swivel	18 — Mold-on Rubber — Roller Bearing	4	B & N — Bolt & Nut Axle
	77 — Rigid	19 — Pneumatic — Ball Bearing	5	
G — Threaded Stem	47 — Rigid	21 — Soft Rubber	6	CDX — “Condux” (Conductive)
	14 — Swivel	27 — Hard Rubber	8	
H — Heavy Duty	34 — Rigid	30 — Phenolic — Delrin or Plain Bearing	10	CT — Zinc Dichromate Finish
	12 — Swivel	31 — Phenolic — Roller Bearing	12	
K — Swivel Stem	32 — Rigid	35 or 35H — Glass Filled Nylon — Roller Bearing	14	GS — Grease Seal
	13 — Swivel	38HD — Heavy Duty Mold-On Polyurethane—Roller Bearing	16	GSS — Grease Seal Swivel Only
N — NSF Approved	33 — Rigid	38HDT — Heavy Duty —Tapered Roller Bearing		GSW — Grease Seal Wheel Only
SHX — Spring Action	15 — Swivel	38 — Mold-on Urethane — Roller Bearing		PL2 — 2 Position Lock
	35 — Rigid	40 — K-Wheel® — Delrin Bearing		PL4 — 4 Position Lock
	16 — Swivel	41 — K-Wheel® — Roller Bearing		R — Riveted Axle
	36 — Rigid	41B —Super K-Wheel® — Precision Ball Bearing		RB — Rollock Brake
	8 — Swivel	41T —Super K-Wheel® — Tapered Roller Bearing		SB — Side Brake
	87 — Rigid	42 — K-Wheel® — Plain Bore		S — Stainless Steel
		43 — K-Wheel® — Precision Ball Bearing		TG — Thread Guard
		60 — Polypropylene Ribbed — Plain Bearing		TB — Total Brake
		61 — Polypropylene Ribbed — Roller Bearing		TSB — Thumb Screw Brake
		60S — Polypropylene — Straight Sided — Plain Bore		V — V-Grooved Wheel
		61S — Polypropylene — Straight Sided — Roller Bearing		WFB — Wheel Face Brake
		64W or 64W-HT — Reinforced Thermoplastic — Plain Bearing		WFCB — Wheel Face Contact Brake
		65W or 65W-HT — Reinforced Thermoplastic — Roller Bearing		ZC — Zinc
		67W or 67W-HT — Reinforced Thermoplastic — Precision Bearing		
		81 — Duraflex — Roller Bearing		
		82 — Duraflex — Ball Bearing		
		90 — Dyna-Tred (TPR) — Delrin Bearing		
		91 — Dyna-Tred (TPR) — Roller Bearing		
		92 — Dyna-Tred (TPR) — Ball Bearing		
		93 — Dyna-Tred (TPR) — Precision Ball Bearing		
		96 — Dyna-Tred (PU) — Delrin Bearing		
		97 — Dyna-Tred (PU) — Ball Bearing		
		98 — Dyna-Tred (PU) — Roller Bearing		
		99 — Dyna-Tred (PU) — Precision Ball Bearing		



Wheel Selection



Semi-Steel

Cast iron toughened with steel, this wheel has a high load rating and exceptionally long wear life. Recommended for wood and concrete floors. D - N/A, TR -40°F to +800°F (With optional high temp grease)



Mold-on Rubber (Vulcanized Rubber Tread)

Cushioned rubber tread permanently vulcanized to a semi-steel core is recommended for quiet movement with heavy loads. D - 75A, TR -40°F to +158°F



Phenolic (Plaskite)

Phenolic compound reinforced with macerated fabric makes a high-strength, high-impact wheel resistant to oil, gasoline, even dilute acids. D - 75D, TR -40°F to +300°F



Mold-on Polyurethane (Duro Tred)

Polyurethane tread permanently vulcanized to a semi-steel core delivers a cushioned ride, excellent mobility, and long wear under heavy loads. D - 95A, TR -40°F to +180°F



K-Wheel

High-strength solid urethane withstands extreme temperatures. Load characteristics of steel with smooth ride. Steam cleanable. Also available with Precision Bearing. D - 55D, TR -50°F to +230°F



Polypropylene (Polyflex)

Polypropylene wheel is light in weight, low in cost, high in impact strength. It resists water and chemical absorption, withstands steam cleaning. D - 60D, TR -20°F to +180°F



RT

Unique waffle design, specially blended reinforced thermoplastic material and specific processing make for a durable, high performance, cost effective wheel. D - 65D, TR -20°F to +250°F
High Temp:
D - 65D, TR -20°F to +480°F



Dyna-Tred TPR

Thermoplastic rubber resists chemicals, high temperatures, and wear. Tough polypropylene hub won't dent, mar, or stain. (Gray Tread) D - 65-70A, TR -40°F to +180°F

* Also Available Super Soft Version - 55A



Dyna-Tred PU

High-load capacity and extended wear. Polyurethane resists chemical absorption. Tough polypropylene hub won't dent, fade, or stain. (Red Tread) D - 100A, TR -40°F to +180°F



Duraflex

Solid cushion tire is puncture proof and impact resistant. Tire is mounted on a rugged corrosion free polypropylene hub. D - 75A, TR -40°F to +158°F



Pneumatic

Tube-type, pressurized tire combines shock absorption with quiet operation and easy rolling. TR -40°F to +158°F

D — Denotes Durometer Hardness

TR — Denotes Temperature Range

Options



Total Lock Brake



Four Position Swivel Lock



Cam-Style Brake



Rollock Brake



Grease Seal



Series 100-500

Load Capacity 90-450 Lbs. Each Caster

Recommended for general warehouse and factory applications such as furniture dollies, laundry carts, bakery racks, and tool boxes; a good combination of strength, durability, and economy.



CASTERS

- **Swivel Casters** — Horn and bearing race way are formed from a single piece of heavy-gauge steel, deeply corrugated to withstand stress and prevent distortion under full rated load
- **Load Bearing** — Single row of hardened, polished ball bearings roll freely in a large-diameter, lubricated raceway
- **Kingpin** — Riveted and coined for durability in rated service
- **Wheel Bearings** — Plain sealed ball bearings and precision bearings
- **Finish** — Corrosion-resistant zinc

Wheel Dia. (In.) (A)	Overall Ht. (In.) (B)	Axle Size (In.)	Swivel Radius (In.) (C)	100 Series Swivel		Mounting Bolt Dia. (In.) Swivel & Rigid	500 Series Rigid	
				Size of Top Plate (In.) (DxE)	Mounting Hole Spacing (In.) (FxG)		Size of Top Plate (In.) (DxE)	Mounting Hole Spacing (In.) (FxG)
2	2 1/2	1/4	1 11/16	1 7/8 x 2 9/16	1 5/16 x 2 1/8	1/4	1 1/2 x 2 21/32	1 5/16 x 2 1/8
2 1/2	3 3/16	5/16	2 1/4	2 3/4 x 3 13/16	1 3/4 x 3	5/16	2 1/4 x 4 7/16	1 1/16 x 3 1/2
3	3 13/16	3/8	2 3/8	3 1/8 x 4 1/8	2 3/8 x 3 3/8 to 3 7/16	5/16	2 1/2 x 4 15/16	1 3/16 x 4
4	5	7/16	3 3/16	4 x 5 1/8	3 x 4	3/8	3 1/8 x 6 1/4	1 3/4 x 5

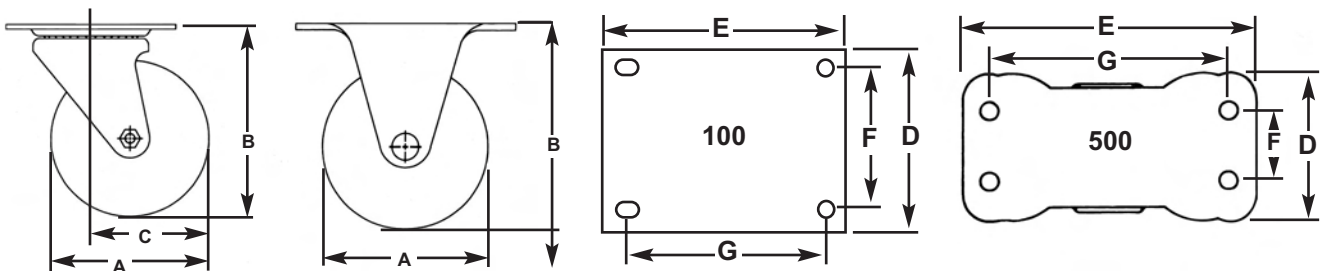

Series 100-500

Load Capacity 90-450 Lbs. Each Caster

Wheel Dia. (In.)	Tread Width (In.)	Wheel Material	Wheel Bearing	Load Rating (Lbs.)	Swivel Caster Desc.	Order No.	Rigid Caster Desc.	Order No.
2	3/4	Dyna-Tred TPR	Delrin	90	190-2R	25030	590-2R	24922
		Dyna-Tred TPR	Delrin	90	190-2RSB	24856	-	-
		Dyna-Tred PU	Delrin	100	196-2R	24873	596-2R	24914
		Dyna-Tred PU	Delrin	100	196-2RSB	24874	-	-
	1	Sintered Iron	Plain	150	108-2R	25028	508-2R	25705
		Soft Rubber	Plain	90	121-2R	25082	521-2R	25748
		Soft Rubber	Plain	90	121-2RSB	25086	-	-
		Hard Rubber	Plain	150	127-2R	25124	527-2R	25783
		Hard Rubber	Plain	150	127-2RSB	25125	-	-
		Polypropylene	Plain	150	160-2R	25190	560-2R	25827
2 1/2	1	Sintered Iron	Plain	200	108-2 1/2 R	25036	508-2 1/2 R	25709
	1 1/8	Soft Rubber	Plain	100	121-2 1/2 R	25083	521-2 1/2 R	25749
		Soft Rubber	Plain	100	121-2 1/2 SB B&N	25160	-	-
		Hard Rubber	Plain	200	127-2 1/2 R	25128	527-2 1/2 R	25785
		Hard Rubber	Plain	200	127-2 1/2 SB B&N	25131	-	-
		Polypropylene	Plain	200	160-2 1/2 R	25188	560-2 1/2 R	25828
3	1 3/16	Sintered Iron	Plain	300	108-3R	25049	508-3R	25713
	1 1/4	Dyna-Tred TPR	Delrin	180	190-3R	24867	590-3R	24915
		Dyna-Tred TPR	Delrin	180	190-3SB B&N	24868	-	-
		Dyna-Tred TPR	Precision	180	193-3RTG	24870	593-3RTG	24917
		Dyna-Tred PU	Delrin	225	196-3R	24875	596-3R	24916
		Dyna-Tred PU	Delrin	225	196-3SB	24876	-	-
		Dyna-Tred PU	Precision	225	199-3RTG	24878	599-3RTG	24918
	1 1/4	Soft Rubber	Plain	175	121-3R	25091	521-3R	25752
		Soft Rubber	Plain	175	121-3SB B&N	25095	-	-
		Hard Rubber	Plain	270	127-3R	25136	527-3R	25787
		Hard Rubber	Plain	270	127-3SB B&N	25151	-	-
		Phenolic	Plain	300	130-3 B&N	25174	530-3 B&N	25812
		Phenolic	Roller	300	131-3 B&N	25179	531-3 B&N	25814
Phenolic		Roller	300	131-3TG B&N	25180	531-3TG B&N	25815	
Polypropylene	Plain	270	160-3R	25189	560-3R	25829		
4	1 5/16	Soft Rubber	Plain	225	121-4R	25098	521-4R	25756
		Soft Rubber	Plain	225	121-4SB B&N	25096	-	-
		Hard Rubber	Plain	350	127-4R	25149	527-4R	25790
		Hard Rubber	Plain	350	127-4SB B&N	25176	-	-
		Polypropylene	Plain	350	160-4R	25191	560-4R	25830
		Polypropylene	Plain	350	160-4R	25191	560-4R	25830
	1 3/8	Sintered Iron	Plain	450	108-4R	25057	508-4R	25717
	1 5/8	Soft Rubber	Plain	240	121-4BR	25100	521-4BR	25760
		Hard Rubber	Plain	420	127-4BR	25153	527-4BR	25793
			Phenolic	Roller	450	131-4 B&N	25181	531-4 B&N

NOTE: Brakes not available on precision bearing wheels

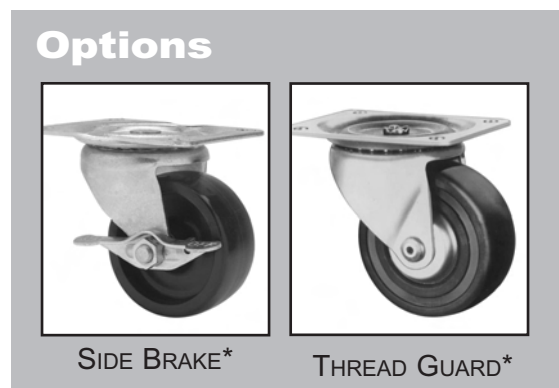

*Side Brake: Foot-operated friction brake positively locks wheel; suffix "SB"

*Thread Guard: Large diameter thread guards prevent loose threads and lint from binding wheel; suffix "TG"



Series 400-7700

Load Capacity 100-400 Lbs. Each Caster

Recommended for tool boxes, bakery racks, dollies, stock trucks, hotel trucks, and other institutional uses requiring good mobility.



CASTERS

- **Swivel Casters** — Heavy-gauge steel top plate is attached to a full-drawn steel horn with hardened raceways
- **Load Bearings** — Two full, independent rows of hardened, polished ball bearings roll freely in large-diameter, lubricated raceways
- **Kingpin** — Fully annealed kingpin holds raceways precisely in alignment
- **Wheel Bearings** — Plain sealed ball bearings and precision bearings
- **Finish**—Corrosion-resistant zinc

Wheel Options



Dyna-Tred TPR
Grey Tread



Dyna-Tred PU
Dark Grey Tread



RT

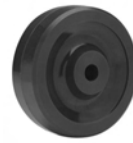

K-Wheel



Hard rubber



Polypropylene



Soft Rubber



Series 400-7700

Load Capacity 100-400 Lbs. Each Caster

Wheel Diameter (A)	2½"	3"	3½"	4"	5"	6"
Overall Height (B)	3⅝"	3⅜"	4¾"	5"	6⅛"	7⅛"
Swivel Radius (C)	2⅝"	2¼"	3⅜"	3⅜"	3⅜"	4⅜"

OPTIONS:

1. Rollock Brake (Add RB Suffix - Ex: 496-4RB) 3½", 4", 5" Swivel Casters only.
2. Thread Guards (Add TG Suffix - Ex: 427-4SB)
3. Side Brake (Add SB Suffix - Ex: 496-4TG)
4. Wheel Face Brake (Add WFB Suffix - Ex: 496-4WFB)

NOTE: Wheel Face Brake should not be used with High Temperature RT Wheel Casters. Bolt and Nut Axle assembly standard on this product line.

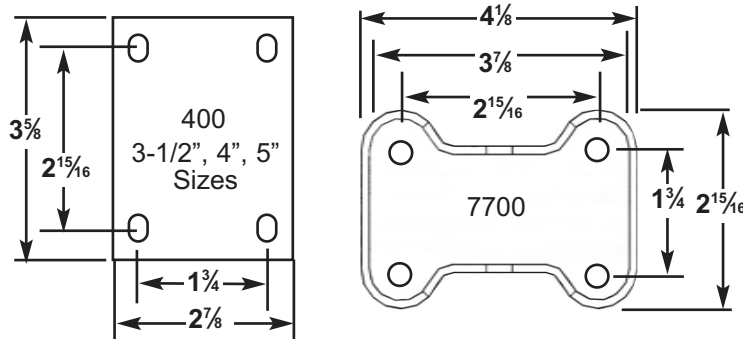
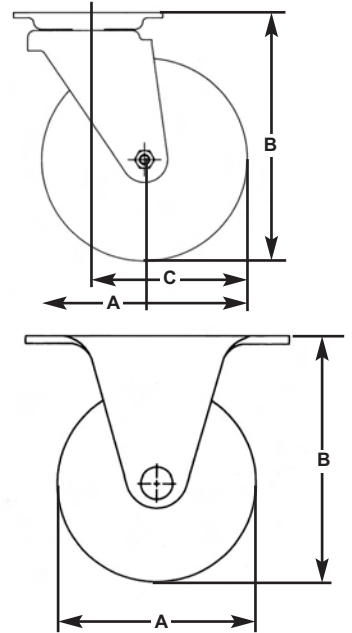

Mounting Bolt Dia. — ⅝"
 Axle Size — ⅜"; *2½"x1⅛" axle size is ⅝"

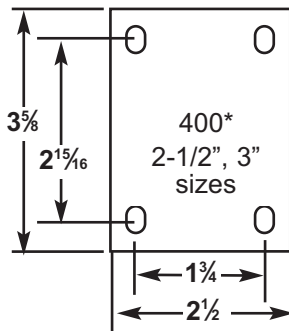

OPTIONAL TOP PLATES

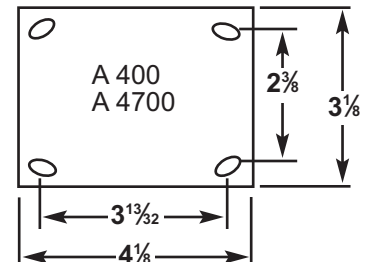
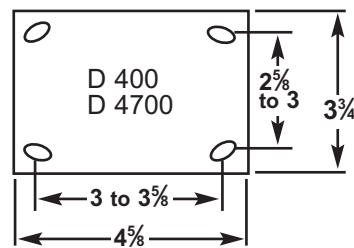

Optional Top Plates: Add "A" or "D" prefix to caster number - Ex: A421-3

*This top plate is also used on H400

Options

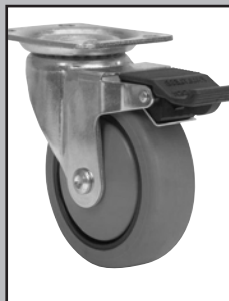

Wheel Face Brake



Side Brake



Thread Guard*



Rollock Brake

*Side Brake: Foot-operated friction brake positively locks wheel; suffix "SB"

*Thread Guard: Large diameter thread guards prevent loose threads and lint from binding wheel; suffix "TG"



Series 400-7700

Load Capacity 100-400 Lbs. Each Caster

Wheel Dia. (In.)	Tread Width (In.)	Wheel Material	Wheel Bearing	Load Rating (Lbs.)	Swivel Caster Desc.	Order No.	Rigid Caster Desc.	Order No.	
2½	1⅛	Soft Rubber	Plain	100	421-2½	25424	7721-2½	25110	
		Hard Rubber	Plain	200	427-2½	25447	7727-2½	25111	
		Polypropylene	Plain	200	460-2½	25436	7760-2½	25112	
3	1¼	Soft Rubber	Plain	175	421-3	24578	7721-3	25113	
		Hard Rubber	Plain	270	427-3	25451	7727-3	25114	
		K-Wheel	Plain	270	442-3	25361	7742-3	25115	
		Polypropylene	Plain	270	460-3	25518	7760-3	25116	
		Dyna-Tred TPR	Delrin	180	490-3	25872	7790-3	27436	
		Dyna-Tred TPR	Precision	180	493-3TG	25873	7793-3TG	27437	
		Dyna-Tred PU	Delrin	225	496-3	25874	7796-3	27433	
		Dyna-Tred PU	Precision	225	499-3TG	25875	7799-3TG	27434	
3½	1¼	Dyna-Tred TPR	Delrin	225	490-3½	25655	7790-3½	27274	
		Dyna-Tred TPR	Precision	225	493-3½TG	25910	7793-3½TG	27169	
		Dyna-Tred PU	Delrin	250	496-3½	25658	7796-3½	27277	
		Dyna-Tred PU	Precision	250	499-3½TG	25911	7799-3½TG	27170	
	1⅝	Soft Rubber	Plain	200	421-3½	25408	7721-3½	25118	
		Soft Rubber	Plain	200	A421-3½TG	25496	A4721-3½TG	27207	
		Hard Rubber	Plain	275	427-3½	25510	7727-3½	25119	
		Hard Rubber	Plain	275	A427-3½	25511	A4727-3½	27208	
		Hard Rubber	Plain	275	D427-3½	25531	D4727-3½	27235	
		Polypropylene	Plain	275	460S-3½	25940	7760S-3½	27191	
	1½	RT Wheel - Standard	Plain	400	464W-3½	25884	7764W-3½	27430	
		RT Wheel - High Temp.	Plain	400	464W-HT-3½	25881	7764W-HT-3½	27427	
4	1¼	Soft Rubber	Plain	200	421-4	25413	7721-4	27280	
		Soft Rubber	Plain	200	A421-4	25532	A4721-4	27213	
		Hard Rubber	Plain	275	427-4	25460	7727-4	25099	
		Hard Rubber	Plain	275	A427-4	25514	A4727-4	27307	
		K-Wheel	Plain	400	442-4	25362	7742-4	25102	
		Polypropylene	Plain	300	460S-4	25475	7760S-4	25105	
		Dyna-Tred TPR	Delrin	250	490-4	25656	7790-4	27275	
		Dyna-Tred TPR	Precision	250	493-4TG	25916	7793-4TG	27233	
	1½	Dyna-Tred PU	Delrin	300	496-4	25659	7796-4	27278	
		Dyna-Tred PU	Precision	300	499-4TG	25917	7799-4TG	27234	
		Polypropylene	Plain	350	A460S-4	25465	A4760S-4	27209	
		RT Wheel - Standard	Plain	400	464W-4	25885	7764W-4	27431	
		RT Wheel - High Temp.	Plain	400	464W-HT-4	25882	7764W-HT-4	27428	
		RT Wheel - High Temp.	Plain	400	A464W-HT-4	25890	-	-	
5	1¼	Soft Rubber	Plain	200	421-5	25533	7721-5	27281	
		Soft Rubber	Plain	200	A421-5	25530	A4721-5	27310	
		Hard Rubber	Plain	300	427-5	25467	7727-5	25109	
		Hard Rubber	Plain	300	A427-5	25506	A4727-5	27313	
		K-Wheel	Plain	400	442-5	25364	7742-5	27299	
		Polypropylene	Plain	350	460S-5	25519	7760S-5	27293	
		Dyna-Tred TPR	Delrin	300	490-5	25657	7790-5	27276	
		Dyna-Tred TPR	Precision	300	493-5TG	25928	7793-5TG	27311	
	1½	Dyna-Tred PU	Delrin	325	496-5	25660	7796-5	27279	
		Dyna-Tred PU	Precision	325	499-5TG	25929	7799-5TG	27312	
		RT Wheel - Standard	Plain	400	464W-5	25886	7764W-5	27432	
		RT Wheel - High Temp.	Plain	400	464W-HT-5	25883	7764W-HT-5	27429	
		2	Polypropylene	Plain	400	460-5	25937	7760-5	27392
			Polypropylene	Plain	400	460-5RB	25971	-	-
6	1⅜	Dyna-Tred TPR	Delrin	325	490-6	25743	4790-6	27257	
		Dyna-Tred TPR	Sealed Ball	325	492-6	25938	4792-6	27251	
		Dyna-Tred PU	Delrin	350	496-6	25979	4796-6	27240	
		Dyna-Tred PU	Sealed Ball	350	497-6	25706	4797-6	27241	

Other wheel materials available. Contact factory. See page 34 for dimensional chart.



Series 1400-3400

Load Capacity 300-1,050 Lbs. Each Caster



This series is the everyday workhorse of our caster line. Its versatility with a broad wheel selection makes it ideal for most general medium-heavy duty industrial applications, such as platform trucks, wire shelving, and other warehouse trucks and carts for commercial use.

- **Top Plate** — Made from $\frac{1}{4}$ " carbon steel, heat treated to give added strength
- **Upper Raceway** — Coined $\frac{5}{16}$ " raceway provides top performance under maximum rated loads
- **Lower Raceway** — $\frac{1}{4}$ " diameter, hardened ball bearings roll freely in a hardened raceway
- **Kingpin** — Cold headed $\frac{3}{4}$ " diameter kingpin holds raceways precisely in alignment
- **Horn Side Members** — Formed steel is welded to cold formed steel upper raceway
- **Wheel Bearings** — Plain, self-lubricating or roller bearings and precision bearings are available
- **Lubrication** — Fittings are installed for both swivel raceway and wheel bearings as required
- **Finish** — Corrosion-resistant zinc

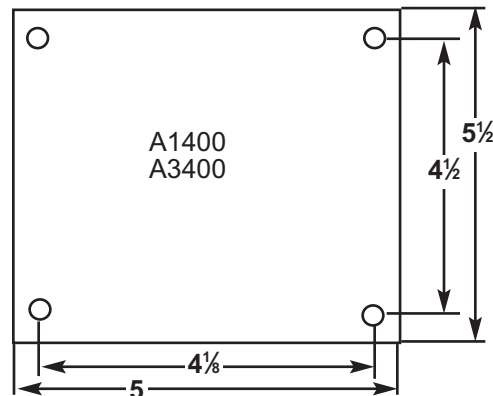
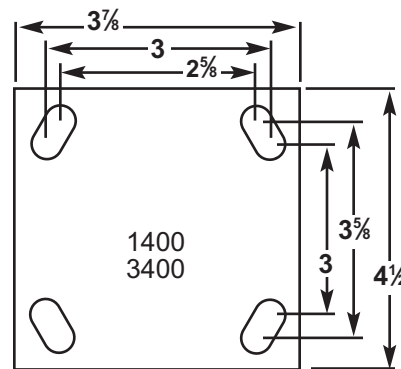

Optional Top Plate:
Add A Prefix - Ex: A1431-6

Refer to page 31 for wheel selections.

CASTERS



Series 1400-3400

Load Capacity 300-1,050 Lbs. Each Caster

Wheel Dia. (In.)	Tread Width (In.)	Wheel Material	Wheel Bearing	Load Rating (Lbs.)	Swivel Caster Desc.	Order No.	Rigid Caster Desc.	Order No.
4	2	Semi-Steel	Roller	700	1406-4x2	26926	3406-4x2	27160
		Mold-on Rubber	Roller	380	1418-4x2	26837	3418-4x2	27127
		RT Wheel - Standard	Delrin	400	1464W-4x2	26221	3464W-4x2	27442
		RT Wheel - High Temp.	H.T. Bushing	400	1464W-HT-4x2	26400	3464W-HT-4x2	27484
		RT Wheel - Standard	Roller	700	1465W-4x2	26222	3465W-4x2	27443
		RT Wheel - High Temp.	Roller	700	1465W-HT-4x2	26401	3465W-HT-4x2	27482
		RT Wheel - Standard	Precision	700	1467W-4x2	26223	3467W-4x2	27444
		RT Wheel - High Temp.	Precision	700	1467W-HT-4x2	26402	3467W-HT-4x2	27485
		Mold-on Polyurethane	Roller	700	1438-4x2	26822	3438-4x2	27159
		K-Wheel	Delrin	700	1440-4x2	26764	3440-4x2	27040
		K-Wheel	Roller	700	1441-4x2	26780	3441-4x2	27045
		K-Wheel	Precision	700	1443-4x2	26897	3443-4x2	27529
		Polypropylene	Plain	400	1460-4x2	26905	3460-4x2	27075
		Polypropylene	Roller	400	1461-4x2	26908	3461-4x2	27079
		Dyna-Tred TPR	Delrin	350	1490-4x2	26212	3490-4x2	27162
		Dyna-Tred TPR	Roller	350	1491-4x2	26214	3491-4x2	27474
		Dyna-Tred TPR	Precision	350	1493-4x2	26903	3493-4x2	27533
		Dyna-Tred PU	Delrin	600	1496-4x2	26213	3496-4x2	27090
		Dyna-Tred PU	Roller	600	1498-4x2	26215	3498-4x2	27475
		Dyna-Tred PU	Precision	600	1499-4x2	26916	3499-4x2	27534
Phenolic	Roller	700	1431-4x2	26819	3431-4x2	27115		
5	2	Semi-Steel	Roller	900	1406-5x2	26814	3406-5x2	27123
		Mold-on Rubber	Roller	380	1418-5x2	26840	3418-5x2	27129
		RT Wheel - Standard	Delrin	650	1464W-5x2	26226	3464W-5x2	27462
		RT Wheel - High Temp.	H.T. Bushing	650	1464W-HT-5x2	26403	3464W-HT-5x2	27486
		RT Wheel - Standard	Roller	900	1465W-5x2	26229	3465W-5x2	27465
		RT Wheel - High Temp.	Roller	900	1465W-HT-5x2	26404	3465W-HT-5x2	27487
		RT Wheel - Standard	Precision	900	1467W-5x2	26232	3467W-5x2	27468
		RT Wheel - High Temp.	Precision	900	1467W-HT-5x2	26405	3467W-HT-5x2	27488
		Mold-on Polyurethane	Roller	900	1438-5x2	26832	3438-5x2	27151
		K-Wheel	Delrin	900	1440-5x2	26768	3440-5x2	27041
		K-Wheel	Roller	900	1441-5x2	26784	3441-5x2	27046
		K-Wheel	Precision	900	1443-5x2	26898	3443-5x2	27530
		Polypropylene	Plain	500	1460-5x2	26906	3460-5x2	27076
		Polypropylene	Roller	500	1461S-5x2	26909	3461S-5x2	27080
		Dyna-Tred TPR	Delrin	450	1490-5x2	26724	3490-5x2	27027
		Dyna-Tred TPR	Roller	450	1491-5x2	26982	3491-5x2	27033
		Dyna-Tred TPR	Precision	450	1493-5x2	26904	3493-5x2	27535
		Dyna-Tred PU	Delrin	750	1496-5x2	26727	3496-5x2	27030
		Dyna-Tred PU	Roller	750	1498-5x2	26985	3498-5x2	27036
		Dyna-Tred PU	Precision	750	1499-5x2	26917	3499-5x2	27536
Phenolic	Delrin	900	1430-5x2	26810	3430-5x2	25073		
Phenolic	Roller	900	1431-5x2	26816	3431-5x2	27114		
6	1½	Duraflex	Roller	300	1481-6x1½	26977	3481-6x1½	27153
	2	Semi-Steel	Roller	900	1406-6x2	26811	3406-6x2	27124
		Mold-on Rubber	Roller	420	1418-6x2	26827	3418-6x2	27111
		RT Wheel - Standard	Delrin	650	1464W-6x2	26227	3464W-6x2	27463
		RT Wheel - High Temp.	H.T. Bushing	650	1464W-HT-6x2	26406	3464W-HT-6x2	27489
		RT Wheel - Standard	Roller	900	1465W-6x2	26230	3465W-6x2	27466
		RT Wheel - High Temp.	Roller	900	1465W-HT-6x2	26407	3465W-HT-6x2	27490
		RT Wheel - Standard	Precision	900	1467W-6x2	26233	3467W-6x2	27469
		RT Wheel - High Temp.	Precision	900	1467W-HT-6x2	26408	3467W-HT-6x2	27491
		Mold-on Polyurethane	Roller	900	1438-6x2	26828	3438-6x2	27120
		K-Wheel	Delrin	900	1440-6x2	26772	3440-6x2	27042

Series 1400-3400

Load Capacity 300-1,050 Lbs. Each Caster

Wheel Dia. (In.)	Tread Width (In.)	Wheel Material	Wheel Bearing	Load Rating (Lbs.)	Swivel Caster Desc.	Order No.	Rigid Caster Desc.	Order No.
6	2	K-Wheel	Roller	900	1441-6x2	26690	3441-6x2	27047
		K-Wheel	Precision	900	1443-6x2	26899	3443-6x2	27531
		Polypropylene	Plain	550	1460-6x2	26885	3460-6x2	27077
		Polypropylene	Roller	550	1461-6x2	26910	3461-6x2	27081
		Dyna-Tred TPR	Delrin	550	1490-6x2	26725	3490-6x2	27028
		Dyna-Tred TPR	Roller	550	1491-6x2	26723	3491-6x2	27155
		Dyna-Tred TPR	Precision	550	1493-6x2	26486	3493-6x2	27398
		Dyna-Tred PU	Delrin	900	1496-6x2	26728	3496-6x2	27031
		Dyna-Tred PU	Roller	900	1498-6x2	26986	3498-6x2	27037
		Dyna-Tred PU	Precision	900	1499-6x2	26771	3499-6x2	27102
		Phenolic	Delrin	900	1430-6x2	26809	3430-6x2	27154
		Phenolic	Roller	900	1431-6x2	26817	3431-6x2	27116
		Ballon	Ball	300	1416-6x2	26801	3416-6x2	27084
8	2	Semi-Steel	Roller	1050	1406-8x2	26813	3406-8x2	27125
		Mold-On Rubber	Roller	500	1418-8x2	26823	3418-8x2	27112
		RT-Wheel - Standard	Delrin	675	1464W-8x2	26228	3464W-8x2	27464
		RT-Wheel -HighTemp.	H.T. Bushing	675	1464W-HT-8x2	26409	3464W-HT-8x2	27496
		RT-Wheel - Standard	Roller	1050	1465W-8x2	26231	3465W-8x2	27467
		RT-Wheel -HighTemp.	Roller	1050	1465W-HT-8x2	26410	3465W-HT-8x2	27497
		RT-Wheel - Standard	Precision	1050	1467W-8x2	26234	3467W-8x2	27470
		RT-Wheel -HighTemp.	Precision	1050	1467W-HT-8x2	26411	3467W-HT-8x2	27498
		Mold-On Polyurethane	Roller	1000	1438-8x2	26829	3438-8x2	27130
		K-Wheel	Delrin	1050	1440-8x2	26776	3440-8x2	27044
		K-Wheel	Roller	1050	1441-8x2	26694	3441-8x2	27048
		K-Wheel	Precision	1050	1443-8x2	26900	3443-8x2	27532
		Polypropylene	Plain	600	1460-8x2	26907	3460-8x2	27078
		Polypropylene	Roller	600	1461-8x2	26911	3461-8x2	27082
		Duraflex	Roller	500	1481-8x2	26979	3481-8x2	27161
		Dyna-Tred TPR	Delrin	700	1490-8x2	26726	3490-8x2	27029
		Dyna-Tred TPR	Roller	700	1491-8x2	26984	3491-8x2	27035
		Dyna-Tred TPR	Precision	700	1493-8x2	26920	3493-8x2	27537
		Dyna-Tred PU	Delrin	1000	1496-8x2	26729	3496-8x2	27032
		Dyna-Tred PU	Roller	1000	1498-8x2	26987	3498-8x2	27038
		Dyna Tred PU	Precision	1000	1499-8x2	26921	3499-8x2	27538
Phenolic	Delrin	1050	1430-8x2	26548	3430-8x2	25053		
Phenolic	Roller	1050	1431-8x2	26818	3431-8x2	27118		

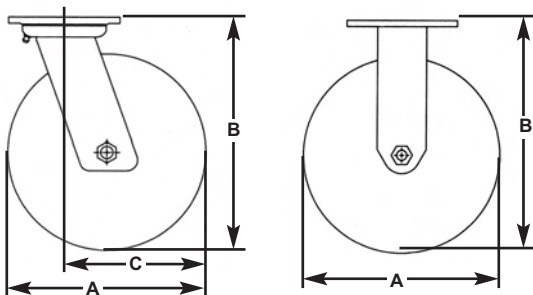

Mounting Bolt Diameter — $\frac{3}{8}$ "

Axle Size — $\frac{1}{2}$ "

Wheel Diameter (A)	4"	5"	6"	8"
Overall Height (B)	5 $\frac{5}{8}$ "	6 $\frac{1}{2}$ "	7 $\frac{1}{2}$ "	9 $\frac{1}{2}$ "
Swivel Radius (C)	3 $\frac{3}{4}$ "	4 $\frac{1}{4}$ "	5"	6 $\frac{1}{2}$ "

OPTIONS:

1. Rollock Brake (Add RB Suffix - Ex: 1491-6RB)
See accessory page 6
2. Grease Seals (Add GS Suffix - Ex: 1491-6GS)
See accessory page 6
3. Cam Style Brake (Add SB Suffix - Ex: 1491-6SB)
See accessory page 7
4. Thread Guard, contact factory (Add TG suffix - Ex: 1491-6TG)
5. PL4 Field Mountable Four Position Swivel Lock available. See accessory page 7
6. Total Lock (Add TB Suffix - Ex: 1491-6TB) See accessory page 7



Stainless Steel 1400/3400

Load Capacity 450-1,050 Lbs. Each Caster

Our popular 1400 series now available in a tough, all-stainless steel construction. Ideal for all demanding medium-heavy duty applications in corrosive environments. S1400 Casters are compatible with the full array of Faultless high performance wheels and accessories. High performance wheels are standard with Delrin bearings for performance in chemicals, oils, or wash down applications.



CASTERS

- **Horn Side Member** — 8-gauge thick stainless steel is welded to cold forged top plate
- **Upper Raceway** — Fully hardened $\frac{5}{16}$ " diameter stainless steel ball bearings in a large diameter raceway provide top performance under maximum rated loads
- **Lower Raceway** — Large diameter, $\frac{1}{4}$ " hardened stainless steel ball bearings roll freely in a large diameter lubricated raceway
- **Kingpin** — Cold headed $\frac{3}{4}$ " diameter kingpin holds raceways precisely in alignment
- **Wheel Bearings** — Plain, Delrin, or sealed roller bearings are also available

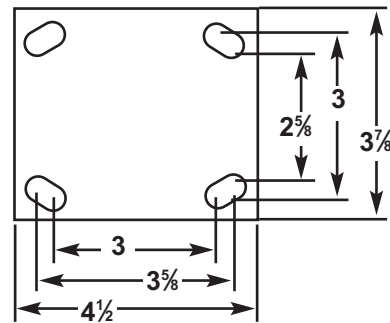
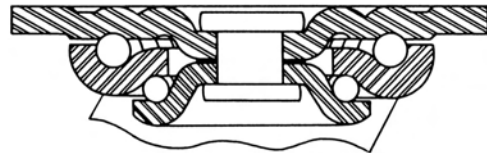

Wheel Options



Dyna-Tred TPR



Dyna-Tred PU



Polypropylene



Phenolic



K-Wheel

RT Wheel

Stainless Steel 1400-3400 Series

Load Capacity 450-1,050 Lbs. Each Caster

Wheel Dia. (In.)	Tread Width (In.)	Wheel Material	Wheel Bearing	Load Rating (Lbs.)	Swivel Caster Desc.	Order No.	Rigid Caster Desc.	Order No.
4	2	K-Wheel	Delrin	700	S1440-4	29441	S3440-4	29521
		Polypropylene	Delrin	450	S1460-4	29443	S3460-4	29523
		RT - Standard	Delrin	600	S1464W-4	29445	S3464W-4	29518
		RT - High Temp.	Plain	600	S1464W-HT-4	29446	S3464W-HT-4	29519
		Phenolic	Delrin	600	S1430-4	29440	S3430-4	29520
5	2	K-Wheel	Delrin	900	S1440-5	29461	S3440-5	29541
		Polypropylene	Delrin	500	S1460-5	29463	S3460-5	29543
		RT - Standard	Delrin	650	S1464W-5	26931	S3464W-5	29538
		RT - High Temp.	Plain	650	S1464W-HT-5	29459	S3464W-HT-5	29539
		Dyna-Tred TPR	Delrin	450	S1490-5	29466	S3490-5	29546
		Dyna-Tred PU	Delrin	750	S1496-5	29468	S3496-5	29548
6	2	Phenolic	Delrin	650	S1430-5	29460	S3430-5	29540
		K-Wheel	Delrin	900	S1440-6	29481	S3440-6	29561
		Polypropylene	Delrin	700	S1460-6	29483	S3460-6	29563
		RT - Standard	Delrin	650	S1464W-6	26932	S3464W-6	29558
		RT - High Temp.	Plain	650	S1464W-HT-6	29477	S3464W-HT-6	29559
		Dyna-Tred TPR	Delrin	550	S1490-6	29486	S3490-6	29566
		Dyna-Tred PU	Delrin	900	S1496-6	29488	S3496-6	29568
8	2	Phenolic	Delrin	650	S1430-6	29480	S3430-6	29560
		K-Wheel	Delrin	1050	S1440-8	29501	S3440-8	29581
		Polypropylene	Delrin	800	S1460-8	29503	S3460-8	29583
		RT - Standard	Delrin	675	S1464W-8	29510	S3464W-8	29578
		RT - High Temp.	Plain	675	S1464W-HT-8	29499	S3464W-HT-8	29579
		Dyna-Tred TPR	Delrin	700	S1490-8	29506	S3490-8	29586
Dyna-Tred PU	Delrin	1000	S1496-8	29508	S3496-8	29588		
		Phenolic	Delrin	675	S1430-8	29500	S3430-8	29580

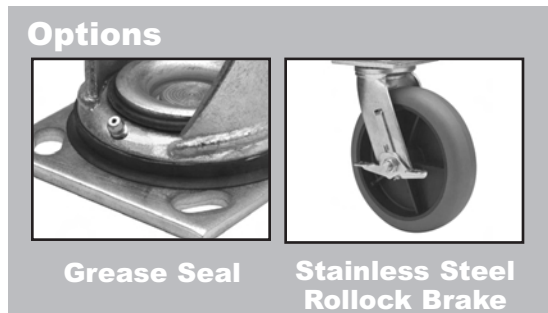
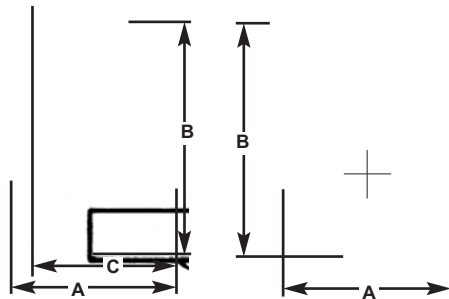

Wheel Diameter (A)	4"	5"	6"	8"
Overall Height (B)	5 ⁵ / ₈ "	6 ¹ / ₂ "	7 ¹ / ₄ "	9 ¹ / ₂ "
Swivel Radius (C)	3 ³ / ₄ "	4 ¹ / ₄ "	5"	6 ¹ / ₈ "

OPTIONS:

1. Rollock Brake (Add RB Suffix - Ex: S1430-8RB) Available in 4", 5", 6", 8".
See accessory page 6.
2. Grease Seals (Add GS Suffix - Ex: S1430-8GS)
See accessory page 6.
3. Lube fittings optional.
4. Stainless Steel ball bearings available with some wheels.

Mounting Bolt Diameter — ³/₈", Axle Size — ¹/₂"



Series H1400-H3400

Load Capacity 420-1,800 Lbs. Each Caster

This series recommended for heavy-duty trucks, dollies, platform trucks, and a variety of equipment used in industry. Both upper and lower raceways are hardened to resist wear for added life.



CASTERS

- **Top Plate** — Extra-thick $\frac{5}{16}$ " carbon steel, heat-treated for added strength and durability in severe service
- **Yoke** — Cold formed $\frac{1}{4}$ " steel, notched for optional 4-position lock
- **Kingpin** — An extra-heavy $\frac{7}{8}$ " diameter king pin assembly aligns raceway
- **Upper Raceway** — $\frac{7}{16}$ " diameter hardened ball bearings
- **Lower Raceway** — $\frac{5}{16}$ " diameter hardened ball bearings
- **Formed Side Members** — Cold formed from $\frac{1}{4}$ " steel for added strength, then welded to the yoke base
- **Wheel Bearings** — Large diameter industrial-grade roller bearings are standard for all wheel sizes
- **Heavy-Duty Axle** — Solid $\frac{1}{2}$ " diameter axle with lock nut for quick easy wheel replacement

- **Lubrication** — Fittings are installed for both swivel raceway and wheel bearings as required
- **Finish** — Corrosion-resistant zinc

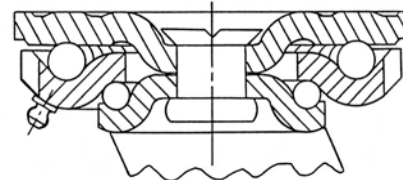
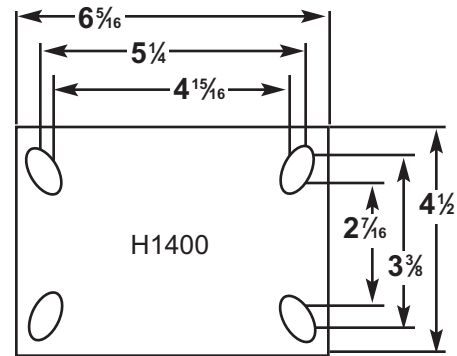

Wheel Options



Dyna-Tred TPR



Dyna-Tred PU



RT



Super-K



Phenolic



Semi-Steel



HD Mold-on Polyurethane



Mold-on Polyurethane



Mold-on Rubber

Series H1400-H3400

Load Capacity 420-1,800 Lbs. Each Caster

Wheel Dia. (In.)	Tread Width (In.)	Wheel Material	Wheel Bearing	Load Rating (Lbs.)	Swivel Caster Desc.	Order No.	Rigid Caster Desc.	Order No.		
6	2	Semi-Steel	Roller	1200	H1406-6x2	26600	H3406-6x2	26625		
		Polyurethane	Roller	1250	H1438-6x2	26609	H3438-6x2	26634		
		Phenolic	Roller	1200	H1431-6x2	26606	H3431-6x2	26631		
		Mold-on Rubber	Roller	420	H1418-6x2	26603	H3418-6x2	26628		
		Super K	Precision	1500	H1441B-6x2	26240	H3441B-6x2	26748		
		RT	Roller	1200	H1465W-6x2	26254	H3465W-6x2	27493		
		Dyna-Tred TPR	Roller	550	H1491-6x2	26236	H3491-6x2	26656		
		Dyna-Tred PU	Roller	900	H1498-6x2	26238	H3498-6x2	26661		
	2½	Semi-Steel	Roller	1600	H1406-6x2½	26612	H3406-6x2½	26637		
		Mold-on Polyurethane	Roller	1600	H1438-6Hx2½	26622	H3438-6Hx2½	26646		
		Phenolic	Roller	1600	H1431-6x2½	26618	H3431-6x2½	26643		
		Mold-on Rubber	Roller	600	H1418-6x2½	26615	H3418-6x2½	26640		
		8	2	Semi-Steel	Roller	1500	H1406-8x2	26601	H3406-8x2	26626
				Mold-on Polyurethane	Roller	1500	H1438-8x2	26610	H3438-8x2	26635
Phenolic	Roller			1400	H1431-8x2	26607	H3431-8x2	26632		
Mold-on Rubber	Roller			500	H1418-8x2	26604	H3418-8x2	26629		
Super K	Precision			1800	H1441B-8x2	26242	H3441B-8x2	26750		
Dyna-Tred PU	Roller			1000	H1498-8x2	26239	H3498-8x2	26663		
Dyna-Tred TPR	Roller			700	H1491-8x2	26237	H3491-8x2	26660		
RT	Roller			1400	H1465W-8x2	26322	H3465W-8x2	27494		
2½	Semi-Steel		Roller	1600	H1406-8x2½	26613	H3406-8x2½	26638		
	Mold-on Polyurethane		Roller	1600	H1438-8Hx2½	26621	H3438-8Hx2½	26647		
	Phenolic	Roller	1600	H1431-8x2½	26619	H3431-8x2½	26644			
	Mold-on Rubber	Roller	800	H1418-8x2½	26616	H3418-8x2½	26641			
10	2½	Semi-Steel	Roller	1800	H1406-10x2½	26614	H3406-10x2½	26639		
		Mold-on Polyurethane	Roller	1800	H1438-10Hx2½	26623	H3438-10Hx2½	26648		
		Mold-on Rubber	Roller	800	H1418-10x2½	26617	H3418-10x2½	26642		

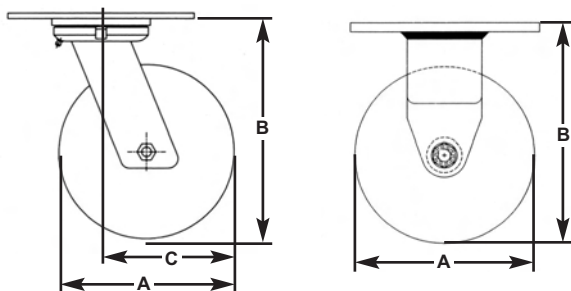

Wheel Diameter (A)	6"	8"	10"
Overall Height (B)	7½"	10⅞"	11½"
Swivel Radius (C)	5⅜"	6⅜"	7⅜"

NOTE: Four Position Swivel Lock, Field Mountable, see page 7.
(Add PL4 Suffix - Ex: H1406-8x2PL4)

Mounting Bolt Diameter — ½"
Axle Size — ½"

Options

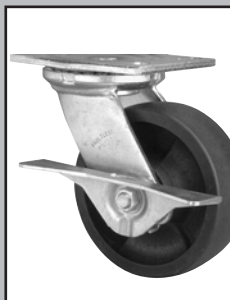

Cam-Style Wheel Brake

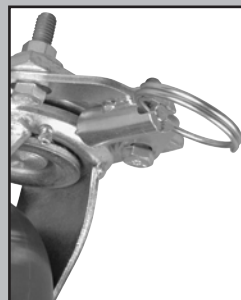

Four Position Swivel Lock



WHEEL SELECTION GUIDE

MATERIAL	FLOOR SURFACE											CONDITIONS				
	Asphalt	Brick & Ceramic Tile	Concrete	Epoxy	Hardwood	Linoleum & Comp. Tile	Steel, Ribbed	Steel, Smooth	Terrazzo	Wood Block & Planking	Mild Chemicals	Harsh Chemicals	Small Metal Scraps	Large Metal Scraps	Excessive Heat (+160° F)	Excessive Cold (-20° F)
Ruberex (Soft Rubber) Pg. 80	•	•	•	•	•	•	•	•	•	•	•	•	•	•		
Dyna-Tred TPR/Dyna-Tred II TPR (Thermoplastic Rubber on Polypropylene) Pg. 69-70	•	•	•	•	•	•	•	•	•	•	•	•	•	•		
Mold-on Rubber on semi-steel Pg. 75	•	•	•	•	•	•	•	•	•	•	•	•	•	•		
Plaskite (Phenolic) Pg. 82	•	•	•	•	•			•	•	•	•	•			•	•
Polyflex (Polypropylene) Pg. 78	•	•	•	•	•	•		•	•	•	•	•	•	•		
Rockite (Hard Rubber) Pg. 81	•	•		•	•			•	•	•	•	•	•			
Dyna-Tred PU (Polyurethane on Polypropylene) Pg. 71	•	•	•	•	•	•	•	•	•	•	•	•	•	•	•	•
Mold-on Polyurethane on semi-steel Pg. 74	•	•	•	•	•	•	•	•	•	•	•	•	•	•	•	•
HD Mold-on Polyurethane Pg. 74	•	•	•	•	•	•	•	•	•	•	•	•	•	•	•	•
K-Wheel (Solid Urethane) Pg. 73	•	•	•	•	•	•	•	•	•	•	•	•	•	•	•	•
Super K-Wheel (Solid Urethane with Steel Sleeve) Pg. 72	•	•	•	•	•	•	•	•	•	•	•	•	•	•	•	•
Cast Iron Pg. 76				•			•	•	•	•	•	•		•	•	
Duraflex (Solid Cushioned Rubber Tire) Pg. 79	•	•	•	•	•	•	•	•	•	•	•	•	•	•		
Pneumatic Pg. 79	•	•	•	•	•	•	•	•	•	•	•	•	•	•		
High Impact Glass Filled Nylon Pg. 90-92	•	•	•	•	•		•	•	•	•	•	•	•	•	•	•
Hot Drop Forged (Steel) Pg. 77				•			•	•	•	•	•	•	•	•	•	•
Sintered Iron Pg. 77				•			•	•	•	•	•	•	•	•	•	•
Balloon Wheel Pg. 79	•	•	•	•	•	•	•	•	•	•	•	•	•	•		
RT Wheel (Standard) Pg. 68	•	•	•	•	•	•	•	•	•	•	•	•	•	•	•	•
RT Wheel (High Temperature) Pg. 68-69	•	•	•	•	•	•	•	•	•	•	•	•	•	•	•	•

Wheel Selection Guide



OUTSIDE DIA.

1⁵/₈" - 5"

2" - 8"

4" - 12"

3" - 12"

1⁵/₈" - 8"

1⁵/₈" - 5"

2" - 8"

4" - 12"

6" - 12"

3" - 8"

5" - 12"

3" - 12"

6" - 12"

6" - 16"

3" - 8"

6" - 10"

2" - 4"

6"

3¹/₂" - 8"

3¹/₂" - 8"

WHEEL CAPACITY

70 - 300 lbs.

80-700 lbs.

240 - 1,150 lbs.

300 - 3,500 lbs.

200 - 600 lbs.

100 - 450 lbs.

90 - 1,000 lbs.

600 - 3,500 lbs.

1,760 - 4,900 lbs.

300 - 1,500 lbs.

1,100 - 4,200 lbs.

300 - 4,000 lbs.

300 - 600 lbs.

250 - 515 lbs.

300 - 1,500 lbs.

6,500 - 17,000 lbs.

150 - 450 lbs.

300 lbs.

600 - 1,400 lbs.

600 - 1,400 lbs.

SERIES

9000, E Series, 100, 400

9000, E Series, 400, 800, 1400, H

C1400, H, KP, HX

100, 400, 1400, H

9000, E Series, 100, 400, 1400

9000, E Series, 100, 400

9000, E Series, 400, 1400, H

1400, H

1400, H

400, 800, KPL, 1400, H

1400, H, HX

100, H

1400

400, 1400

300, 1400

100

400, 1400

400, 1400, H1400

400, 1400, H1400

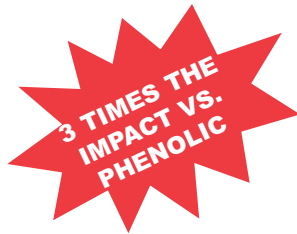

REINFORCED THERMOPLASTIC

RT Standard Wheels

Load Capacity 600 - 1400 Lbs. Each Wheel

Reinforced Thermoplastic material and specific processing create this high performance, durable, and cost effective wheel. The RT series of wheels, designed for use in the Faultless 1400 and 400 Series Casters, are ideally suited for food processing, tool storage, sanitary maintenance, and applications requiring easy mobility under heavy loads. They are extremely resistant to water, chemical absorption, and steam cleaning. Standard wheel operating temperature range is -20°F to +250°F and the High Temperature version range is -20°F to +480°F. Durometer is 65D.



WHEELS

Wheel Dia. (In.)	Tread Width (In.)	Load Rating (Lbs.)	Hub Length*	Axle Size					64W	65W	67W	64W
				Plain Bore Size	Bore Size With Roller Bearing	Bore Size With Precision Bearing	Bore Size With Bearing Spanner	Bore Size With Delrin Bushing	Plain Bore Order No.	Roller Bearing Order No.	Precision Bearing Order No.	Delrin Bushing Order No.
3½	1½	600	1 1/16	1 3/16	3/4	-	3/8	3/4	44332	37679	-	37678
		600	1 1/16	1/2	-	-	-	-	44334	-	-	-
		600	1 1/16	3/8	-	-	-	-	44335	-	-	-
4	1½	700	1 1/16	1 3/16	3/4	-	3/8	3/4	44336	37690	-	37689
		700	1 1/16	3/4	-	-	-	-	44337	-	-	-
		700	1 1/16	1/2	-	-	-	-	44338	-	-	-
		700	1 1/16	3/8	-	-	-	-	44339	-	-	-
5	2	800	2 3/16	1 3/16	3/4	5/8	1/2	3/4	44241	42913	42923	42892
		800	1 1/16	1 3/16	3/4	-	3/8	3/4	44341	37692	-	37691
5	1½	800	1 1/16	1/2	-	-	-	-	44343	-	-	-
		800	1 1/16	3/8	-	-	-	-	44344	-	-	-
		1000	2 3/16	1 3/16	3/4	5/8	1/2	3/4	44271	42914	42917	42908
6	2	1200	2 3/16	1 3/16	3/4	5/8	1/2	3/4	44254	42915	42918	42909
8	2	1400	2 3/16	1 3/16	3/4	5/8	1/2	3/4	44276	42916	42919	42910

RT High-Temp Wheels

Load Capacity 600 - 1400 Lbs. Each Wheel

Wheel Dia. (In.)	Tread Width (In.)	Load Rating (Lbs.)	Hub Length*	Axle Size					64W	65W	67W	64W
				Plain Bore Size	Bore Size With Roller Bearing	Bore Size With Precision Bearing	Bore Size With Bearing Spanner	Bore Size With Delrin Bushing	Plain Bore Order No.	Roller Bearing Order No.	Precision Bearing Order No.	Delrin Bushing Order No.
3½	1½	600	1 1/16	1 3/16	3/4	-	3/8	-	43975	37660	-	-
		600	1 1/16	1/2	-	-	-	-	44352	-	-	-
4	1½	700	1 1/16	1 3/16	3/4	-	3/8	-	43976	37661	-	-
		700	1 1/16	1/2	-	-	-	-	44353	-	-	-
5	2	800	2 3/16	1 3/16	3/4	5/8	1/2	3/4	44210	37904	42934	43979
		800	1 1/16	1 3/16	3/4	-	3/8	-	43977	37662	-	-
5	1½	800	1 1/16	1/2	-	-	-	-	44354	-	-	-
		1000	2 3/16	1 3/16	3/4	5/8	1/2	3/4	44211	37905	42935	43980
6	2	1200	2 3/16	1 3/16	3/4	5/8	1/2	3/4	44212	37906	42936	43981
8	2	1400	2 3/16	1 3/16	3/4	5/8	1/2	3/4	44213	37907	42937	43982

• Roller Bearing for 3/8" Bore requires Spanner #41781. Spanner can be used in either standard or high temperature version.
 • 1/2" Plain Bore reduced to 3/8" Bore requires Spanner #41840.
 See Heat Deflection Chart on Next Page.

Heat Deflection vs. Time for High Temp RT Wheels

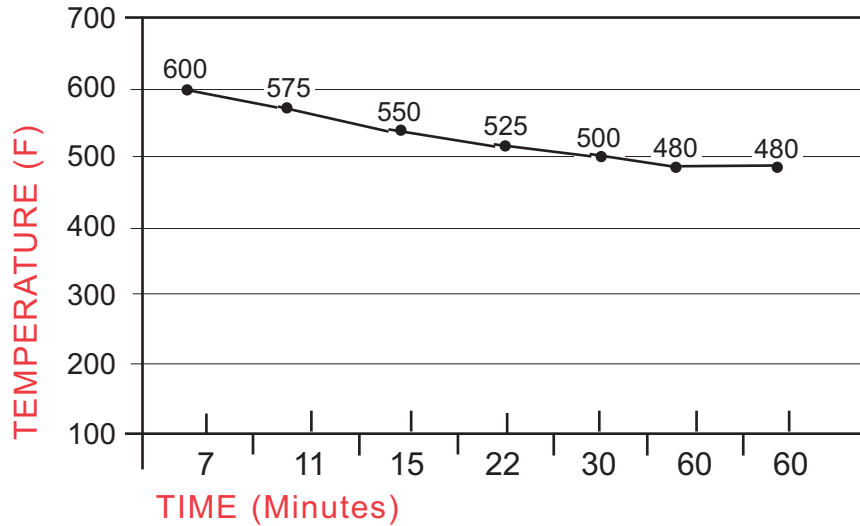

Data Table	
Faultless High Temp. RT Whls.	
Temperature (F)	Length of Time
480	Continuous Usage
500	Intermittent 30 Min/ Hr. usage
550	Intermittent 15 Min/ Hr. usage
600	Intermittent at 7-10 Min/ Hr. usage

WHEELS

Dyna-Tred II

Load Capacity 80-125 Lbs. Each Wheel

Dyna-Tred II wheels, second generation of already proven and tested Dyna-Tred wheels, add a new variety of alternatives for wheels in E-Series casters. These wheels have the same chemical interlocking tread as its larger Dyna-Tred counterparts. These wheels give dollies, furniture, carts, and trucks a whole new look and ride.



Wheel Dia. (In.)	Tread Width (In.)	Load Capacity (Lbs.)	Hub Length (In.)	Axle Size (In.)	Use With Swivel Caster Series	Wheel Desc.	Order No.
2	3/4	80	29/32	1/4	EW, ER, EK, EP, EY	1-2x3/4	47122
2 1/2	13/16	80	29/32	1/4	EW, ER, EK, EP, EY	1-2 1/2 x 13/16	47123
3	13/16	90	1 1/4	1/4	EW, ER, EK, EP, EY	1-3x13/16	47104
4	15/16	115	1 5/32	5/16	EW, ER, EK, EP, EY	1-4x15/16	47135
5	15/16	125	1 5/32	5/16	EW, ER, EK, EP, EY	1-5x15/16	47140

Note: Thread Guards are optional; Gray thermoplastic tread on black polypropylene core is standard. If spanner required, order separately. Plain bearing standard.



THERMOPLASTIC RUBBER-ON POLYPROPYLENE

Dyna-Tred TPR Wheels

Load Capacity 180-700 Lbs. Each Wheel

Thermoplastic rubber resists chemicals, caustics, oils, acids, and wear. Rugged polypropylene hub won't dent, mar, fade or stain. Tread and hub are double bonded and mechanically interlocked to eliminate tread separation. Gives dollies, carts and trucks a soft and cushioned non-marking ride. Temperature operating range is -40°F to +180°F. Durometer is 70A.



WHEELS

Wheel Dia. (In.)	Tread Width (In.)	Load Rating (Lbs.)	Hub Length (In.)	Axle Size			Use With Swivel Caster Series	Precision Bearing Desc.	Order No.	Ball Bearing Desc.	Order No.	Delrin Bearing Desc.	Order No.	Roller Bearing Desc.	Order No.
				Without Bearing	With Bearing and Spanner	With Bearing, No Spanner									
3	1 1/4	180	1 1/16	-	-	3/8	100,400	93-3x1 1/4 TG	42970	-	-	-	-	-	-
		180	1 1/16	-	-	3/8	100,400	-	-	-	-	90-3x1 1/4	42966	-	-
3 1/2	1 1/4	225	1 1/16	-	-	3/8	400	93-3 1/2 x 1 1/4 TG	42971	-	-	-	-	-	-
		225	1 1/16	-	-	3/8	400	-	-	-	-	90-3 1/2 x 1 1/4	42967	-	-
4	1 1/4	250	1 1/16	-	-	3/8	400	93-4x1 1/4 TG	42972	-	-	-	-	-	-
		250	1 1/16	-	-	-	400	-	-	-	-	90-4x1 1/4	42968	-	-
	350	2 3/8	-	1/2	3/8	1400	93-4x2	45794	-	-	-	-	-	-	
	350	2 3/8	-	1/2	3/4	1400	-	-	-	-	90-4x2	45795	-	-	
5	1 1/4	300	1 1/16	-	-	3/8	400	93-5x1 1/4 TG	42973	-	-	-	-	-	-
		300	1 1/16	-	-	3/8	400	-	-	-	-	90-5x1 1/4	42969	-	-
	450	2 3/8	-	1/2	3/8	1400	93-5x2	42947	-	-	-	-	-	-	
	450	2 3/8	1 3/16	1/2	3/4	1400	-	-	-	-	90-5x2	44074	-	-	
	450	2 3/8	1 3/16	1/2	3/4	1400	-	-	-	-	-	-	91-5x2	44223	
6	1 1/4	325	1 3/16	-	-	3/8	400	-	-	92-6x1 1/4	44064	-	-	-	-
		325	1 3/16	-	-	3/8	400	-	-	-	-	90-6x1 1/4	43920	-	-
	550	2 3/8	-	1/2	5/8	1400	93-6x2	44249	-	-	-	-	-	-	
	550	2 3/8	1 3/16	1/2	3/4	1400	-	-	-	-	90-6x2	44075	-	-	
8	1 1/4	550	2 3/8	1 3/16	1/2	3/4	1400	-	-	-	-	-	-	91-6x2	43965
		550	2 3/8	1 3/16	1/2	3/4	1400	-	-	-	-	-	-	-	-
	700	2 3/8	-	1/2	5/8	1400	93-8x2	45078	-	-	-	-	-	-	-
	700	2 3/8	1 3/16	1/2	3/4	1400	-	-	-	-	90-8x2	44077	-	-	
8	2	700	2 3/8	1 3/16	1/2	3/4	1400	-	-	-	-	-	-	91-8x2	44222
		700	2 3/8	1 3/16	1/2	3/4	1400	-	-	-	-	-	-	-	-

Note: Gray thermoplastic tread on black polypropylene core is standard. If spanner required, order separately. Special Top Hat Spanner used with Precision Bearing. Wheels with 2" tread width. *Black Tread with Gray Core

Also Available - Super Soft Version - 55A

Bearing Options



Top Hat Spanner



Precision



Delrin



Roller

POLYURETHANE ON POLYPROPYLENE



Dyna-Tred PU Wheels

Load Capacity 225-1,000 Lbs. Each Wheel

Polyurethane tread for high load capacity and extended wear. Protects floors and resists chemicals, caustics, acids, and oils. Rugged polypropylene hub will not dent, mar, fade, or stain. Tread and hub are mechanically inter-locked to eliminate tread separations. Temperature operating range is -40°F to +180°F. Durometer is 90A.

Wheel Dia. (In.)	Tread Width (In.)	Load Rating (Lbs.)	Hub Length (In.)	Axle Size			Use With Swivel Caster Series	Precision Bearing Desc.	Order No.	Ball Bearing Desc.		Delrin Bearing Desc.		Roller Bearing Desc.	
				Without Bearing	With Bearing and Spanner	With Bearing, No Spanner				Order No.	Order No.	Order No.	Order No.		
3	1 1/4	225	1 1/16	-	-	3/8	100,400	99-3x1 1/4 TG	42978	-	-	-	-	-	-
		225	1 1/16	-	-	3/8	100,400	-	-	-	-	96-3x1 1/4	42974	-	-
3 1/2	1 1/4	250	1 1/16	-	-	3/8	400	99-3 1/2 x 1 1/4 TG	42979	-	-	-	-	-	-
		250	1 1/16	-	-	3/8	400	-	-	-	-	96-3 1/2 x 1 1/4	42975	-	-
4	1 1/4	300	1 1/16	-	-	3/8	400	99-4x1 1/4 TG	42980	-	-	-	-	-	-
		300	1 1/16	-	-	-	400	-	-	-	-	96-4x1 1/4	42976	-	-
	2	600	2 3/8	-	1/2	5/8	1400	99-4x2	42949	-	-	-	-	-	-
		600	2 3/8	-	1/2	3/4	1400	-	-	-	-	96-4x2	45797	-	-
		600	2 3/8	-	1/2	3/4	1400	-	-	-	-	-	-	98-4x2	45798
5	1 1/4	325	1 1/16	-	-	3/8	400	99-5x1 1/4 TG	42981	-	-	-	-	-	-
		325	1 1/16	-	-	3/8	400	-	-	-	-	96-5x1 1/4	42977	-	-
	2	750	2 3/8	-	1/2	5/8	1400	99-5x2	42950	-	-	-	-	-	-
		750	2 3/8	1 3/16	1/2	3/4	1400	-	-	-	-	96-5x2	44081	-	-
		750	2 3/8	1 3/16	1/2	3/4	1400	-	-	-	-	-	-	98-5x2	44172
6	1 3/8	350	1 1/16	-	-	3/8	400	-	-	97-6x1 3/8	44076	-	-	-	-
		350	1 1/16	1 1/8	3/8	1/2	400	-	-	-	-	96-6x1 3/8	42111	-	-
	2	900	2 3/8	-	1/2	5/8	1400	99-6x2	42162	-	-	-	-	-	-
		900	2 3/8	1 3/16	1/2	3/4	1400	-	-	-	-	96-6x2	44083	-	-
		900	2 3/8	1 3/16	1/2	3/4	1400	-	-	-	-	-	-	98-6x2	44175
8	2	1000	2 3/8	-	1/2	5/8	1400	99-8x2	42164	-	-	-	-	-	-
		1000	2 3/8	1 3/16	1/2	3/4	1400	-	-	-	-	96-8x2	44100	-	-
		1000	2 3/8	1 3/16	1/2	3/4	1400	-	-	-	-	-	-	98-8x2	44170

Note: If spanner required, order separately. Red polyurethane on black polypropylene core is standard on 2" wide wheels. Gray on black standard on 1 1/4" wide wheels.

Bearing Options



Top Hat Spanner



Precision



Delrin



Roller

WHEELS



Super K

Load Capacity 1100-4200 Lbs. Each Caster

The Faultless Super-K is molded from a polyether-based polyurethane material that resists compression set, rejects foreign objects, and has excellent resiliency for ease of movement in manual or in tow applications. The Super-K wheel will outperform all competition by combining a mechanically locked solid steel hub with precision grade bearings. For severe axial loadings, try our tapered bearing assembly. Temperature operating range is -50°F to +180°F. Durometer is 55D. Standard color is Blue.



WHEELS

Wheel Dia. (In.)	Tread Width (In.)	Load Rating (Lbs.)	Hub Length (In.)	Axle Size		Radial Ball Bearing Desc.	Order No.	Tapered Bearing Desc.	Order No.	
				With Spanner*	With Bearing, No Spanner					
5	2	1100	2¼	½	-	41B-5x2	37887	-	-	
	2	1500	2¼	½	-	41B-6x2	37877	-	-	
6	2½	1620	¾	¾	-	41B-6x2½	37914	-	-	
	3	2500	¾	¾	-	41B-6x3	37917	-	-	
		2500	¾	-	1¼	-	-	-	41T-6x3	62675
8	2	1800	2¼	½	-	41B-8x2	37879	-	-	
	2½	2000	¾	¾	-	41B-8x2½	37915	-	-	
	3	2500	¾	¾	-	41B-8x3	37918	-	-	
		2500	¾	-	1	-	-	-	41T-8x3	62676
		2500	¾	-	1¼	-	-	-	41T-8x3	62677
10	2½	2500	¾	¾	-	41B-10x2½	37916	-	-	
	3	3000	¾	¾	-	41B-10x3	37919	-	-	
		3000	¾	-	1¼	-	-	-	41T-10x3	62681
	4	4200	4¼	-	1¼	-	-	41T-10x4	62683	
12	3	3400	¾	¾	-	41B-12x3	37921	-	-	

*Spanner included with all ball bearing Super K-Wheels

NOTE: Capacity ratings are based on intermittent service with speeds up to 5 mph. Speeds from 5 to 10 mph reduce capacity by 20%.

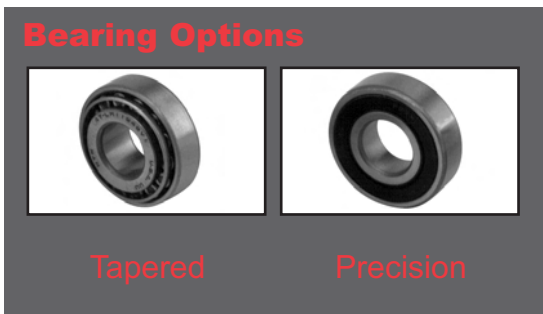

K-Wheel

Load Capacity 300-1,500 Lbs. Each Wheel



The K-Wheel is molded from a high strength urethane compound which possesses the load characteristics of steel but gives the smooth effortless ride you expect from polyurethane. Solid wheel has no plastic or metal core thereby eliminating any possibility of tread separation. It is not affected by blood, brine, greases, oils, or most harsh chemicals. It's steam cleanable. Temperature operating range is -50°F to +180°F. Durometer is 55D. Standard color is blue.

Wheel Dia. (In.)	Tread Width (In.)	Load Rating (Lbs.)	Hub Length (In.)	Axle Size			Use With Swivel Caster Series	Precision Bearing Desc.	Order No.	Delrin Bearing Desc.	Order No.	Roller Bearing Desc.	Order No.	Plain Bore Desc.	Order No.
				Without Bearing	With Bearing No Spanner	With Bearing and Spanner									
3	1 1/4	300	1 9/16	1/2	-	3/8	400	-	-	-	-	-	-	42-3x1 1/4	44182
	1 1/4	500	1 9/16	1/2	-	3/8	400	-	-	-	-	-	-	42-4x1 1/4	44185
4	2	700	2 3/16	1 3/16	3/4	1/2	1400	-	-	40-4x2	41999	-	-	42-4x2	44191
		700	2 3/16	1 3/16	3/4	1/2	1400	-	-	-	-	41-4x2	42002	-	-
	700	2 3/16	1 3/16	5/8	1/2	1400	43-4x2	42911	-	-	-	-	-	-	-
	1 1/4	700	1 9/16	1/2	-	3/8	400	-	-	-	-	-	-	42-5x1 1/4	44195
5	2	1000	2 3/16	1 3/16	3/4	1/2	1400	-	-	-	-	-	-	42-5x2	44198
		1000	2 3/16	1 3/16	3/4	1/2	1400	-	-	40-5x2	42003	-	-	-	-
		1000	2 3/16	1 3/16	3/4	1/2	1400	-	-	-	-	41-5x2	42005	-	-
		1000	2 3/16	1 3/16	5/8	1/2	1400	43-5x2	42920	-	-	-	-	-	-
	1200	2 3/16	1 3/16	3/4	1/2	1400	-	-	-	-	-	-	-	42-6x2	44200
6	2	1200	2 3/16	1 3/16	3/4	1/2	1400	-	-	40-6x2	42012	-	-	-	-
		1200	2 3/16	1 3/16	3/4	1/2	1400	-	-	-	-	41-6x2	42014	-	-
		1200	2 3/16	1 3/16	5/8	1/2	1400	43-6x2	42922	-	-	-	-	-	-
		1500	2 3/16	1 3/16	3/4	1/2	1400	-	-	-	-	-	-	42-8x2	44202
8	2	1500	2 3/16	1 3/16	3/4	1/2	1400	-	-	40-8x2	42016	-	-	-	-
		1500	2 3/16	1 3/16	3/4	1/2	1400	-	-	-	-	41-8x2	42018	-	-
		1500	2 3/16	1 3/16	5/8	1/2	1400	43-8x2	42912	-	-	-	-	-	-

If spanner required, order separately.

NOTE: Autoclave/Anti-Static material available. Contact Factory.

Capacity ratings on precision bearing wheels are based on intermittent service with speeds up to 5 mph. Speeds from 5 to 10 mph reduce capacity by 20%.

Bearing Options



Top Hat Spanner



Precision



Delrin



Roller

WHEELS



Duro-Tred Vulcanized Wheels

Load Capacity 700-4,950 Lbs. Each Wheel

Polyurethane tread permanently attached to a metal core delivers a cushioned ride, excellent mobility, and extended life under extremely heavy loads. Duro-Tred wheels protect floors and loads better and will wear four to ten times longer than other wheel materials. Standard with roller bearings. Temperature operating range is -40°F to +180°F. Durometer rating is 95A in standard.



WHEELS

Wheel Dia. (In.)	Tread Width (In.)	Load Rating (Lbs.)	Hub Length (In.)	Axle Size			Use With Swivel Caster Series	Wheel Desc.	Order No.
				Without Roller Bearing	With Bearing, No Spanner	With Bearing and Spanner			
4	2	700	2 ³ / ₁₆	1 ³ / ₁₆	³ / ₄	¹ / ₂	1400	38-4x2	37870
5	2	1000	2 ³ / ₁₆	1 ³ / ₁₆	³ / ₄	¹ / ₂	1400	38-5x2	37860
6	2	1250	2 ³ / ₁₆	1 ³ / ₁₆	³ / ₄	¹ / ₂	1400	38-6x2	37863
		1760	2 ³ / ₁₆	1 ³ / ₁₆	³ / ₄	¹ / ₂		38HD-6x2	37940
	2 ¹ / ₂	1600	2 ⁷ / ₈	1 ³ / ₁₆	³ / ₄	¹ / ₂	H	38-6Hx2 ¹ / ₂	37791
		1650	3 ¹ / ₄	1 ¹⁵ / ₁₆	1	³ / ₄		38-6x2 ¹ / ₂	37795
	3	2150	3 ¹ / ₄	1 ¹⁵ / ₁₆	1	³ / ₄		38HD-6x2 ¹ / ₂	37941
		2100	3 ¹ / ₄	1 ¹⁵ / ₁₆	1	³ / ₄		38-6x3	37801
8	2	2450	3 ¹ / ₄	1 ¹⁵ / ₁₆	1	³ / ₄	H	38HD-6x3	37942
		1500	2 ³ / ₁₆	1 ³ / ₁₆	³ / ₄	¹ / ₂	1400	38-8x2	37865
	2 ¹ / ₂	2200	2 ³ / ₁₆	1 ³ / ₁₆	³ / ₄	¹ / ₂	1400	38HD-8x2	37943
		1600	2 ⁷ / ₈	1 ³ / ₁₆	³ / ₄	¹ / ₂	H	38-8Hx2 ¹ / ₂	37793
	3	2100	3 ¹ / ₄	1 ¹⁵ / ₁₆	1	³ / ₄		38-8x2 ¹ / ₂	37796
		2600	3 ¹ / ₄	1 ¹⁵ / ₁₆	1	³ / ₄		38HD-8x2 ¹ / ₂	37944
10	2 ¹ / ₂	2500	3 ¹ / ₄	1 ¹⁵ / ₁₆	1	³ / ₄		38-8x3	37802
		3350	3 ¹ / ₄	1 ¹⁵ / ₁₆	1	³ / ₄		38HD-8x3	37945
	3	1800	2 ⁷ / ₈	1 ³ / ₁₆	³ / ₄	¹ / ₂	H	38-10Hx2 ¹ / ₂	37794
		2500	3 ¹ / ₄	1 ¹⁵ / ₁₆	1	³ / ₄		38-10x2 ¹ / ₂	37797
	3	3100	3 ¹ / ₄	1 ¹⁵ / ₁₆	1	³ / ₄		38HD-10x2 ¹ / ₂	37947
		3000	3 ¹ / ₄	1 ¹⁵ / ₁₆	1	³ / ₄		38-10x3	37803
12	2 ¹ / ₂	4150	3 ¹ / ₄	1 ¹⁵ / ₁₆	1	³ / ₄		38HD-10x3	37948
		2700	3 ¹ / ₄	1 ¹⁵ / ₁₆	1	³ / ₄		38-12x2 ¹ / ₂	37800
	3	3550	3 ¹ / ₄	1 ¹⁵ / ₁₆	1	³ / ₄		38HD-12x2 ¹ / ₂	37950
		3500	3 ¹ / ₄	1 ¹⁵ / ₁₆	1	³ / ₄		38-12x3	37804
		4950	3 ¹ / ₄	1 ¹⁵ / ₁₆	1	³ / ₄		38HD-12x3	37951

If spanner required, order separately.

Note: Other bearing options available contact factory.



Vulcanized Rubber Tread Wheels

Load Capacity 380-1,870 lbs. Each Wheel

Cushioned rubber tread permanently vulcanized to a semi-steel core is recommended for quiet movement with heavy loads. Molded core provides added strength with a reinforced, double-thick hub. Vulcanized rubber-tread wheels are standard with roller bearings. Temperature operating range is -40°F to +158°F. Durometer rating is 75A.

Wheel Dia. (In.)	Tread Width (In.)	Load Rating (Lbs.)	Hub Length (In.)	Axle Size			Use With Swivel Caster Series	Tread Wheel Desc.	Order No.
				Without Roller Bearing	With Bearing, No Spanner	With Bearing and Spanner			
4	2	380	2 ³ / ₁₆	1 ³ / ₁₆	³ / ₄	¹ / ₂	1400	18-4x2	37810
5	2	380	2 ³ / ₁₆	1 ³ / ₁₆	³ / ₄	¹ / ₂	1400	18-5x2	37813
6	2	420	2 ³ / ₁₆	1 ³ / ₁₆	³ / ₄	¹ / ₂	H, CPA	18-6x2	37861
		770	2 ¹ / ₄	1 ³ / ₁₆	³ / ₄	-		18HD-6x2	61488
	2 ¹ / ₂	600	2 ⁷ / ₈	1 ³ / ₁₆	³ / ₄	¹ / ₂	H	18-6Hx2 ¹ / ₂	37769
		600	3 ¹ / ₄	1 ¹⁵ / ₁₆	1	³ / ₄		18-6x2 ¹ / ₂	37773
	3	700	3 ¹ / ₄	1 ¹⁵ / ₁₆	1	³ / ₄		18-6x3	37779
		1050	3 ¹ / ₄	1 ¹³ / ₁₆	1	-		18HD-6x3	61489
8	2	500	2 ³ / ₁₆	1 ³ / ₁₆	³ / ₄	¹ / ₂	H, CPA	18-8x2	37891
		1000	2 ¹ / ₄	1 ³ / ₁₆	³ / ₄	-		18-8HDx2	61490
	2 ¹ / ₂	800	2 ⁷ / ₈	1 ³ / ₁₆	³ / ₄	¹ / ₂	H	18-8Hx2 ¹ / ₂	37770
		800	3 ¹ / ₄	1 ¹⁵ / ₁₆	1	³ / ₄		18-8x2 ¹ / ₂	37774
	3	1100	3 ¹ / ₄	1 ¹³ / ₁₆	1	-		18-8HDx2 ¹ / ₂	61491
		850	3 ¹ / ₄	1 ¹⁵ / ₁₆	1	³ / ₄		18-8x3	37780
10	2 ¹ / ₂	1200	3 ¹ / ₄	1 ¹³ / ₁₆	1	-		18-8HDx3	61492
		800	2 ⁷ / ₈	1 ³ / ₁₆	³ / ₄	¹ / ₂	H	18-10Hx2 ¹ / ₂	37772
	3	900	3 ¹ / ₄	1 ¹⁵ / ₁₆	1	³ / ₄		18-10x2 ¹ / ₂	37776
		1150	3 ¹ / ₄	1 ¹³ / ₁₆	1	-		18-10HDx2 ¹ / ₂	61493
	3	1000	3 ¹ / ₄	1 ¹⁵ / ₁₆	1	³ / ₄		18-10x3	37781
		1650	3 ¹ / ₄	1 ¹³ / ₁₆	1	-		18-10HDx3	61494
12	2 ¹ / ₂	900	3 ¹ / ₄	1 ¹⁵ / ₁₆	1	³ / ₄		18-12x2 ¹ / ₂	37777
		1550	3 ¹ / ₄	1 ¹³ / ₁₆	1	-		18HD-12x2 ¹ / ₂	61507
	3	1150	3 ¹ / ₄	1 ¹⁵ / ₁₆	1	³ / ₄		18-12x3	37783
		1870	3 ¹ / ₄	1 ¹³ / ₁₆	1	-		18HD-12x3	61508

NOTE: Roller Bearings are standard. If spanner required, order separately.

WHEELS



Cast Iron

Load Capacity 700-4,000 Lbs. Each Wheel

Semi-Steel — Cast iron toughened with steel, this wheel has extremely high load ratings and exceptionally long wear life. It's recommended for rough wood and concrete floors – a good choice for moving heavy loads in manufacturing and warehousing. Long-life features include a heavy tread and plain or roller bearings. Ideal in extreme operating temperature ranges of -40°F to +800°F with optional high temperature grease.



WHEELS

Wheel Dia. (In.)	Tread Width (In.)	Load Rating (Lbs.)	Hub Length (In.)	Axle Size				Use With Swivel Caster Series	Roller Bearing Desc.	Order No.
				Without Roller Bearing	Plain Bearing	With Bearing, No Spanner	With Bearing and Spanner			
4	2	700	2 ³ / ₈	1 ³ / ₁₆	1/2	3/4	1/2	1400	06-4x2	37715
5	2	1000	2 ³ / ₈	1 ³ / ₁₆	1/2	3/4	1/2	1400	06-5x2	37716
6	2	1200	2 ³ / ₈	1 ³ / ₁₆	-	3/4	1/2	1400, H	06-6x2	37721
	2 1/2	1600	2 ⁷ / ₈	1 ³ / ₁₆	-	3/4	1/2	H	06-6Hx2 1/2	37748
		2500	3 1/4	1 ¹⁵ / ₁₆	-	1	3/4		06-6x2 1/2	37751
	3	2500	3 1/4	1 ¹⁵ / ₁₆	-	1	3/4		06-6x3	37755
8	2	1500	2 ³ / ₈	1 ³ / ₁₆	-	3/4	1/2	1400, H	06-8x2	37733
	2 1/2	1600	2 ⁷ / ₈	1 ³ / ₁₆	-	3/4	1/2	H	06-8Hx2 1/2	37749
		2500	3 1/4	1 ¹⁵ / ₁₆	-	1	3/4		06-8x2 1/2	37752
	3	2800	3 1/4	1 ¹⁵ / ₁₆	-	1	3/4		06-8x3	37759
10	2 1/2	1800	2 ⁷ / ₈	1 ³ / ₁₆	-	3/4	1/2	H	06-10Hx2 1/2	37750
		2500	3 1/4	1 ¹⁵ / ₁₆	-	1	3/4		06-10x2 1/2	37753
	3	3000	3 1/4	1 ¹⁵ / ₁₆	-	1	3/4		06-10x3	37761
12	2 1/2	3000	3 1/4	1 ¹⁵ / ₁₆	-	1	3/4		06-12x2 1/2	37754
	3	4000	3 1/4	1 ¹⁵ / ₁₆	-	1	3/4		06-12x3	37765

Bearing Options



Steel Caged Roller

NOTE: Roller bearing versions equipped with plastic cage bearings. If temperature exceeds 300° contact factory. If spanner required, order separately.

Sintered Iron

Load Capacity 150-450 Lbs. Each Wheel



Sintered Iron — Powdered iron, compacted and sintered to cast-iron strength, makes a concentric and smooth tread. Standard with plain bearings. Temperature operating range is -40°F to +500°F.

Wheel Dia. (In.)	Tread Width (In.)	Load Rating (Lbs.)	Hub Length (In.)	Axle Size (In.)	Use With Caster Series	Wheel Desc.	Order No.
2	$1\frac{5}{16}$	150	1	$\frac{1}{4}$	100	08-2x1	44035
2½	1	200	$1\frac{3}{8}$	$\frac{5}{16}$	100	08-2½x1	43820
3	$1\frac{3}{16}$	300	$1\frac{9}{16}$	$\frac{3}{8}$	100	08-3x1¾	43925
4	$1\frac{3}{8}$	450	$1\frac{15}{16}$	$\frac{7}{16}$	100	08-4x1¾	43926

WHEELS



Polyflex

Load Capacity 200-600 Lbs. Each Wheel

This polypropylene wheel has a light weight, low cost, high impact strength. It resists water and chemical absorption, even stands up to repeated steam cleaning. Non-marking tread provides excellent floor protection. Polypropylene is one of the strongest and most economical wheels in many caster applications. It's available with plain or roller bearings. Temperature operating range is -20°F to +180°F. Durometer is 60D.

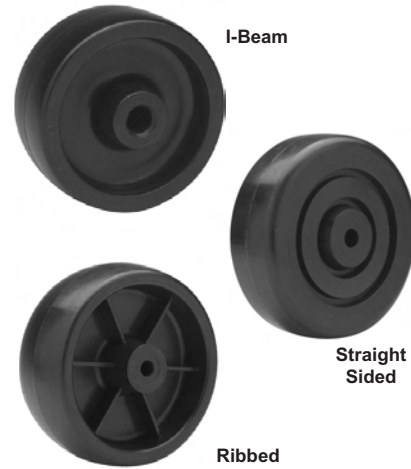

WHEELS

Wheel Dia. (In.)	Tread Width (In.)	Load Rating (Lbs.)	Hub Length (In.)	Axle Size			Use With Swivel Caster Series	Plain Bearing Desc.	Order No.	Roller Bearing Desc.	Order No.	
				With Plain Bearing	With Bearing, No Spanner	With Bearing and Spanner						
2½	1⅛	200	1⅜	5/16	-	-	100, 400	60-2½x1⅛	45060	-	-	
3	1¼	270	1⅙	3/8	-	-	100, 400	60-3x1¼	43183	-	-	
3½	1¼	275	1⅙	3/8	-	-	400	60S-3½x1¼	45767	-	-	
		275	1⅙	½	-	-	400	60S-3½x1¼	45766	-	-	
4	1⅙	400	1 ²⁹ / ₃₂	7/16	-	-	100	60-4x1⅙	45068	-	-	
		300	1⅙	3/8	-	-	400	60S-4x1¼	45769	-	-	
	300	1⅙	½	-	-	400	60S-4x1¼	45768	-	-		
	1½	350	1⅙	3/8	-	-	400	60S-4x1½	45771	-	-	
		350	1⅙	½	-	-	400	60S-4x1½	45770	-	-	
	350	1⅙	350	1⅙	½	½	3/8	400	-	-	61S-4x1½	45772
			400	2¼	3/4	-	-	1400	60-4x2	43102	-	-
	2	2⅜	400	2⅜	1⅙	3/4	½	1400	-	-	61-4x2	43467
350			1⅙	3/8	-	-	400	60S-5x1¼	45785	-	-	
5	1¼	350	1⅙	1⅙	½	3/8	400	-	-	61S-5x1¼	45783	
		400	1⅙	3/8	-	-	400	60S-5x1½	45774	-	-	
	1½	400	1⅙	½	-	-	400	60S-5x1½	45773	-	-	
		500	2⅜	½	-	-	1400	60S-5x2	45786	-	-	
	2	2⅜	500	2⅜	3/4	-	-	1400	60S-5x2	45776	-	-
			500	2⅜	½	-	-	1400	60-5x2 Rib	43997	-	-
		500	2⅜	1⅙	3/4	½	1400	-	-	61-5x2 Rib	43135	
		500	2⅜	3/4	-	-	1400	60-5x2 Rib	43129	-	-	
6	2	550	2⅜	3/4	-	-	1400	60S-6x2	45778	-	-	
		550	2⅜	1⅙	3/4	½	1400	-	-	61S-6x2	45793	
	550	2⅜	½	-	-	1400	60-6x2 Rib	47995	-	-		
	550	2⅜	3/4	-	-	1400	60-6x2 Rib	43944	-	-		
	550	2⅜	1⅙	3/4	½	1400	-	-	61-6x2 Rib	43137		
	600	2⅜	3/4	-	½	1400	60-8x2	43138	-	-		
8	2	600	2⅜	1⅙	3/4	½	1400	-	-	61-8x2	43139	

DURAFLEX & PNEUMATIC WHEELS



Duraflex

Load Capacity 300 - 600 Lbs. Each Wheel



Duraflex wheels are solid cushion tires made from a special blend of granular rubber and chemical accelerators, cured under tremendous pressure. The result is a “bouncy” high impact resistant and puncture proof wheel. Tires are mounted on rugged polypropylene centers which will not dent or rust like conventional metal hubs. Ideal for hand trucks or other equipment which requires a soft, cushioned ride. Durometer is 80A.

Wheel Dia. (In.)	Tread Width (In.)	Wheel Bearing	Bore (In.)	Centered Or Offset	Hub Length (In.)	Load Rating (Lbs.)	Wheel Desc.	Order No.
6	1½	Roller	¾*	C	2¼	300	181-6x1½	44154
8	2	Roller	¾*	C	2¼	500	181-8x2	44155
		Ball	⅝	Off	2¼	500	182-8x225x2¼ Off-⅝	44144
	2¼	Ball	¾	Off	2¼	500	182-8x225x2¼ Off-¾	44145
		Ball	⅝	C	2½	500	182-8x225x2½-⅝	44146
		Ball	¾	C	2½	500	182-8x225x2½-¾	44147
10	2½	Ball	⅝	Off	2¼	550	182-10x250x2¼ Off-⅝	44148
		Ball	¾	Off	2¼	550	182-10x250x2¼ Off-¾	44149
		Ball	⅝	C	3¼	550	182-10x250x3¼-⅝	44150
		Ball	¾	C	3¼	550	182-10x250x3¼-¾	44151
12	3	Ball	⅝	C	3¼	600	182-12x300x3¼-⅝	44153
		Ball	¾	C	3¼	600	182-12x300x3¼-¾	44152

NOTE: Specify for 1400 Series ¾" bore without spanner bushing; for ½" bore order spanner bushing EDP No. 41878



Pneumatic

Load Capacity 125-515 Lbs. Each Wheel

This Faultless wheel provides a cushioned ride for delicate instruments and breakable items. The tube-type, pressurized tire combines shock absorption with quiet operation and easy rolling. Standard with ball bearings.

Nominal Dia. (In.)	Ply Rating	Bore (In.)	Wheel Bearing	Hub Width (In.)	Hub Color	Load Rating (Lbs.)	Tread Style	Wheel Desc.	Order No.
6	4	½	Ball	2¼ ₁₆	Silver	125	Sawtooth	119-6x2BLK	44131
6	4	½	Ball	2¼ ₁₆	Silver	125	Sawtooth	119-6x2GRY	44142
8	4	½	Ball	3¼	Silver	300	Sawtooth	119-8x2.50	44104
10	4	½	Ball	4	Silver	350	Sawtooth	119-10x3.50	44121
12	4	½	Ball	4¼ ₁₆	Silver	450	Sawtooth	119-12x3.50	44125
16	2	⅝	Ball	6	Red	515	Ribbed	4.80x4.00x8x⅝BP	20578

NOTE: All of the above Pneumatic wheels are centered. Contact Factory for Gray Wheel, Wheel Desc. 119-8x250, Order #44118

WHEELS



Ruberex®

Load Capacity 70-240 Lbs. Each Wheel

This composition rubber wheel combines a soft rubber tread with a hard rubber core for quiet movement, a cushioned ride, and maximum floor protection. Temperature operating range is -40°F to +158°F. Durometer is 75A.



WHEELS

Wheel Dia. (In.)	Tread Width (In.)	Load Rating (Lbs.)	Hub Length (In.)	Axle Size				Use With Swivel Caster Series	Plain Bearing Desc.	Order No.
				Without Roller Bearing	Plain Bearing	With Bearing No Spanner	With Bearing and Spanner			
1 ⁵ / ₈	4 ⁷ / ₆₄	70	3/4	-	7/32	-	-	9000, EW, EY	4-1 ⁵ / ₈ x 4 ⁷ / ₆₄	47155
2	7/8	80	1 ⁵ / ₁₆	-	1/4	-	-	9000, EW, EY	4-2x 7/8	47163
	1	90	1 ¹ / ₆₄	-	1/4	-	-	100	21-2x 1	47172
2 ¹ / ₂	1 ³ / ₁₆	80	2 ⁹ / ₃₂	-	1/4	-	-	W, EW, EY	4-2 ¹ / ₂ x 1 ³ / ₁₆	47173
	1 ¹ / ₈	100	1 ³ / ₈	-	5/16	-	-	100, 400	21-2 ¹ / ₂ x 1 ¹ / ₈	47231
3	1 ³ / ₁₆	90	1 ¹ / ₆₄	-	1/4	-	-	9000, EP	4-3x 1 ³ / ₁₆	47175
	1 ¹ / ₄	175	1 ⁹ / ₁₆	1 ¹ / ₁₆	3/8	1/2	3/8	100, 400	21-3x 1 ¹ / ₄	47238
3 ¹ / ₂	1 ⁵ / ₁₆	200	1 ⁹ / ₁₆	-	3/8	-	-	400	21-3 ¹ / ₂ x 1 ⁵ / ₁₆	44216
4	1 ⁵ / ₁₆	115	1 ⁵ / ₃₂	-	5/16	-	-	EK, EP, EW, EY	4-4x 1 ⁵ / ₁₆	47200
	1 ¹ / ₄	200	1 ⁹ / ₁₆	-	3/8	-	-	400	21-4x 1 ¹ / ₄	47250
	1 ⁵ / ₁₆	225	1 ¹⁵ / ₁₆	1 ¹ / ₁₆	7/16	5/8	7/16	100	21-4x 1 ⁵ / ₁₆	47244
	1 ⁵ / ₈	240	1 ¹⁵ / ₁₆	1 ¹ / ₁₆	7/16	5/8	7/16	100	21-4Bx 1 ⁵ / ₈	47269
5	1 ⁵ / ₁₆	125	1 ⁵ / ₃₂	-	5/16	-	-	EK, EP, EY	4-5x 1 ⁵ / ₁₆	47218
	1 ¹ / ₄	200	1 ⁹ / ₁₆	-	3/8	-	-	400, K, G	21-5x 1 ¹ / ₄	47259

HARD RUBBER



Rockite®

Load Capacity 100-420 Lbs. Each Wheel



Hard-rubber molded composition. It combines many desirable characteristics: high-load rating, good mobility, high-impact resistance, and good floor protection. Temperature operating range is -40°F to 158°F. Durometer is 75D.

Wheel Dia. (In.)	Tread Width (In.)	Load Rating (Lbs.)	Hub Length (In.)	Axle Size				Use With Swivel Caster Series	Plain Bearing Desc.	Order No.
				Without Roller Bearing	Plain Bearing	With Bearing, No Spanner	With Bearing and Spanner			
2	1	150	1 ¹ / ₆₄	-	1/4	-	-	100	27-2x1	47329
2 ¹ / ₂	1 ¹ / ₈	200	1 ³ / ₈	-	5/16	-	-	100, 400	27-2 ¹ / ₂ x1 ¹ / ₈	47330
3	1 ³ / ₁₆	100	1 ¹ / ₆₄	-	1/4	-	-	EP	7-3x1 ³ / ₁₆	47293
	1 ¹ / ₄	270	1 ⁹ / ₁₆	1 ¹ / ₁₆	3/8	-	-	100, 400	27-3x1 ¹ / ₄	47336
3 ¹ / ₂	1 ⁵ / ₁₆	275	1 ⁹ / ₁₆	-	3/8	-	-	400	27-3 ¹ / ₂ x1 ⁵ / ₁₆	43543
4	1 ⁵ / ₁₆	125	1 ⁵ / ₃₂	-	5/16	-	-	EP, EY	7-4x1 ⁵ / ₁₆	47316
	1 ¹ / ₄	275	1 ⁹ / ₁₆	-	3/8	-	-	400	27-4x1 ¹ / ₄	47346
	1 ⁵ / ₁₆	350	1 ¹⁵ / ₁₆	1 ¹ / ₁₆	7/16	-	-	100	27-4x1 ⁵ / ₁₆	47341
	1 ⁵ / ₈	420	1 ¹⁵ / ₁₆	1 ¹ / ₁₆	7/16	-	-	100	27-4Bx1 ⁵ / ₈	47372
5	1 ⁵ / ₁₆	135	1 ⁵ / ₃₂	-	5/16	-	-	EP, EY	7-5x1 ⁵ / ₁₆	47327
	1 ¹ / ₄	300	1 ⁹ / ₁₆	-	3/8	-	-	400, G	27-5x1 ¹ / ₄	47347

WHEELS



Plaskite®

Load Capacity 300-3,500 Lbs. Each Wheel

Phenolic compound reinforced with macerated fabric makes a high-strength, high-impact wheel resistant to oil, gasoline, even dilute acids. Compression-molded under extreme pressure, these wheels gain a dense, uniform consistency. Phenolic wheels are non-marking, non-conductive, and spark-proof. They are available with plain or roller bearings. Will not warp or swell in a temperature operating range of -40°F to +300°F. Durometer is 75D.



WHEELS

Wheel Dia. (In.)	Tread Width (In.)	Load Rating (Lbs.)	Hub Length (In.)	Axle Size				Use With Swivel Caster Series	Plain Bearing Desc.	Order No.	Roller Bearing Desc.	Order No.
				Without Roller Bearing	Plain Bearing	With Bearing, No Spanner	With Bearing and Spanner					
3	1¼	300	1⅞	-	3/8	-	-	100	30-3x1¼	43838	-	-
		300	1⅞	1⅞	-	1/2	3/8	100	-	-	31-3x1¼	37627
4	1½	500	1⅞	1⅞	-	5/8	7/16	100	-	-	31-4x1⅞	37630
	2	800	2⅞	1⅞	3/4	-	-	1400, H, HX, KP	30-4x2	37629	-	-
		800	2⅞	1⅞	-	3/4	1/2	1400, H, HX, KP	-	-	31-4x2	37636
5	2	1000	2⅞	-	3/4	-	-	1400, H, HX, KP	30-5x2	37638	-	-
		1000	2⅞	1⅞	-	3/4	1/2	1400, H, HX, KP	-	-	31-5x2	37639
6	2	1200	2⅞	-	3/4	-	-	1400, H, HX, KP	30-6x2	37641	-	-
		1200	2⅞	1⅞	-	3/4	1/2	1400, H, HX, KP	-	-	31-6x2	37637
	2½	1600	2¾	1⅞	-	3/4	1/2	H	-	-	31-6Hx2½	37807
		1600	3¼	1⅞	-	1	3/4	1400, HX, KP	-	-	31-6x2½	37816
	3	3000	3¼	1⅞	-	1	3/4	1400, HX, KP	-	-	31-6x3	37820
8	2	1400	2⅞	1⅞	-	3/4	1/2	1400, H, HX, KP	-	-	31-8x2	37643
		2000	2¾	1⅞	-	3/4	1/2	H	-	-	31-8Hx2½	37808
		2000	3¼	1⅞	-	1	3/4	HX, KP	-	-	31-8x2½	37817
	3	2500	3¼	1⅞	-	1	3/4	HX, KP	-	-	31-8x3	37821
10	3	2900	3¼	1⅞	-	1	3/4	HX, KP	-	-	31-10x3	37822
12	2½	3000	3¼	1⅞	-	1	3/4	HX, KP	-	-	31-12x2½	37819
	3	3500	3¼	1⅞	-	1	3/4	HX, KP	-	-	31-12x3	37823

Bearing Options



Steel Caged Roller



Delrin

Note: Hi-Temp version is available with a operating range of 480° continuous, 530° intermittent.

Please see Page 68, RT Wheels, for further high temperature options. If spanner required, order separately.

What Type of Wheel Bearings Do You Use?



1. **Self-Lubricating:** The self-lubricating bearing is an iron base powdered metal bushing press fitted into the wheel core. The powdered iron is porous and is impregnated with oil so that with use, oil is leaked out to lubricate the axle.

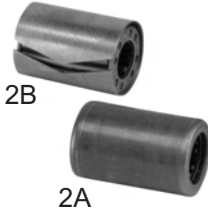

2. **Roller Bearing:** (fig 2A) Normally this is a two-piece bearing, consisting of a roller assembly and a hardened outer race. The split-sleeve bearing (fig 2B) consists of an outer raceway of hardened spring steel with a hardened roller and cage assembly. A full caged bearing assembly (fig 2A) consists of a fully encased outer raceway with a hardened roller and cage assembly. All roller bearings operate in conjunction with a hardened shaft called a spanner.



3. **Tapered Roller Bearing:** The tapered roller precision bearing consists of a cup which is pressed into the wheel hub, and a cone and roller combination which fits integrally into the cup. The cup and core are hardened. The rollers are tilted to react to both thrust and radial loads. These bearings are suited for towline, high speed, and high load applications.



4. **Flanged Radial Ball Bearing:** This is a unique stamped construction that has a one-piece outer raceway, which is cold-rolled and formed to a close tolerance ball groove. The inner raceway is machined and hardened. The bearing is shielded and grease packed. These bearings will react to thrust loading and considerable radial load.



5. **Delrin Bearing:** Delrin is a registered trademark of Dupont; this is an acetal resin molded into a flange type bearing. The bearing is press fitted into the hub of the wheel and is rotated around a hardened spanner. This bearing has high mechanical strength, high impact, low static, and dynamic coefficients of friction, with a wide use temperature range (-40° to +230°F).



6. **Radial Bearing:** This type of sealed precision bearing consists of a hardened outer raceway and inner raceway, separated by a concentric ring of hardened steel balls. This bearing is used in pairs and is usually press fitted into a deep pocket of a wheel that has high load and high speed capabilities. This type of bearing is primarily used to carry radial loads only.

7. **Plain Bearing:** (Not Shown) In a plain bearing, the hub material is actually the bearing. The wheel rotates on a steel axle and is the most economical bearing application.



Air Faultless Casters

Load Capacity 310-450 Lbs. Each Caster

Air Faultless pneumatic wheel casters are designed to absorb shock and vibration caused by floor obstructions or outdoor terrain. Moves delicate industrial loads smoothly and safely over rough bumpy surfaces.



- **Cold Forged Construction** — 3/16" formed steel legs are double welded for added strength under maximum load. Thick 1/4" steel top plate
- **Double Ball Bearing Swivel** — Large diameter main load bearing and thrust bearing assures easy maneuvering under heavy loads
- **4-Ply Tires** — Standard on all wheel sizes provide longer wheel life and fewer repairs
- **Heavy-Duty Steel Hub** — Bolted for extra durability. Ball bearings offer maximum mobility
- **Lube Fittings** — Provided for swivel bearings
- **Finish** — Corrosion-resistant zinc
- **Wheel Tread** — Sawtooth tread design is standard.

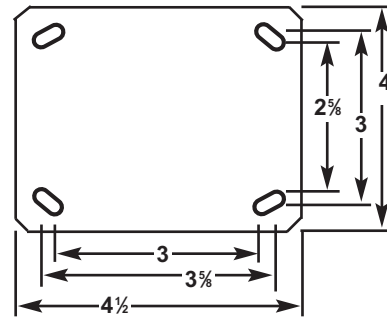
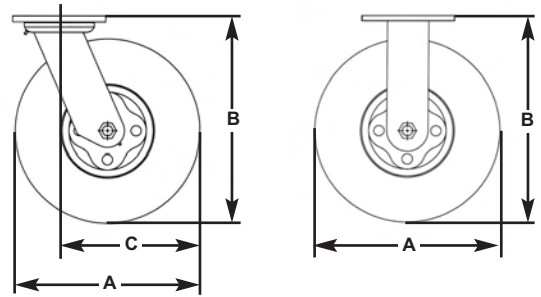

Wheel Dia. (In.)	Tire Size	Wheel Bearing	Load Rating (Lbs.)	Swivel Caster Desc.	Order No.	Rigid Caster Desc.	Order No.
8	2.80/2.50-4	Ball	310	I1419-8 Blk	46110	I3419-8 Blk	46111
	2.80/2.50-4	Ball	310	I1419-8 Gray	46089	I3419-8 Gray	46088
	2.80/2.50-4	Ball	310	I1419-8 Gray/Brk	46085	-	-
	2.80/2.50-4	Ball	310	I1419-8 Black/Brk	48368	-	-
10	4.10/3.50-6	Ball	350	I1419-10 Blk	46112	I3419-10 Blk	46113
	4.10/3.50-6	Ball	350	I1419-10 Gray	46090	I3419-10 Gray	46093
12	4.10/3.50-6	Ball	450	I1419-12 Blk	46114	I3419-12 Blk	46115
	4.10/3.50-6	Ball	450	I1419-12 Gray	46091	I3419-12 Gray	46094

Wheel Diameter (A)	8"	10"	12"
Overall Height (B)	9 ¹⁵ / ₁₆ "	12"	15"
Swivel Radius (C)	6 ³ / ₄ "	8 ⁵ / ₁₆ "	10 ¹ / ₄ "

Mounting Bolt Diameter — 3/8"
Axle Size — 1/2"

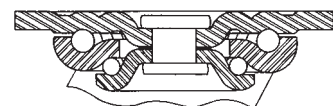

NOTE: Double ball raceway

Airline/Conveyor Casters

Load Capacity 375 Lbs. Each Caster

Precision, Heavy Duty Air Cargo/Conveyor Caster

Designed for inverted applications, these Faultless conveyor casters are designed for easy installation and replacement in the field. Special dust-and-grease cap and special all-temperature lubricant are standard, along with precision bearing swivel and needle bearing wheels. Corrosive-resistant zinc dichromate finish is standard.

- **Special Top Plates** - For specific installation requirements
- **Raceways** - Fully sealed raceways for low maintenance and protection of the swivel head in outdoor environments
- **Swivel Bearings** - Precision bearing swivel
- **Wheel Bearings** - Needle bearings; thread guards standard
- **Finish** - Corrosion-resistant zinc dichromate
- **Suggested Temperature Range** -20°F — +180°F



P2461-2-3/4 RTG
Order #27013
(Diamond Top Plate)

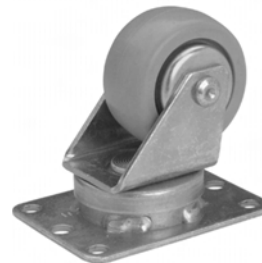

P2461-2-5/8 TG
Order #26025
(Rectangle Top Plate)



P2461-2-5/8 TG
Order #26028
(Diamond Special Top Plate)

Wheel Diameter	Tread Width (In.)	Wheel Type	Wheel Bearing	Axle Size (In.)	Load Capacity (Lbs.)	Overall Height (In.)	Swivel Radius (In.)	Mounting Bolt Dia. (In.)	Order No.	Top Plate
2¾	1¾	Polyflex	Needle	¾	375	4½ ₃₂	2¾	⅝ ₁₆	27013	A

*Gray Polyflex Wheel

Wheel Diameter	Tread Width (In.)	Wheel Type	Wheel Bearing	Axle Size (In.)	Load Capacity (Lbs.)	Overall Height (In.)	Swivel Radius (In.)	Mounting Bolt Dia. (In.)	Order No.	Top Plate
2½	1¾	Polyflex	Needle	¾	375	3 ²⁵ / ₃₂	2 ⁵ / ₁₆	⅝ ₁₆ & ¾	26025	B

*Tan Polyflex Wheel

Wheel Diameter	Tread Width (In.)	Wheel Type	Wheel Bearing	Axle Size (In.)	Load Capacity (Lbs.)	Overall Height (In.)	Swivel Radius (In.)	Mounting Bolt Dia. (In.)	Order No.	Top Plate
2½	1¾	Polyflex	Needle	¾	375	3 ²⁵ / ₃₂	2 ⁵ / ₁₆	⅝ ₁₆ & ¾	26028	C

*Tan Polyflex Wheel



Flanged Air Cargo/Conveyor Caster

Load Capacity 270-375 Lbs. Each Caster

This caster has all the features as the precision, heavy duty air cargo/conveyor caster plus the added benefit of a toe protection flange safety feature.

Wheel Diameter	Tread Width (In.)	Wheel Type	Wheel Bearing	Axle Size (In.)	Load Capacity (Lbs.)	Overall Height (In.)	Swivel Radius (In.)	Mounting Bolt Dia. (In.)	Swivel Caster Desc.	Order No.	Top Plate
2 $\frac{3}{4}$	1 $\frac{3}{8}$	Polyflex	Needle	$\frac{3}{8}$	375	4 $\frac{1}{32}$	2 $\frac{13}{16}$	$\frac{5}{16}$	PF2461-2 $\frac{3}{4}$ RTG	26382*	A
2 $\frac{5}{8}$	1 $\frac{3}{8}$	Polyflex	Needle	$\frac{3}{8}$	375	3 $\frac{25}{32}$	2 $\frac{7}{16}$	$\frac{5}{16}$ & $\frac{3}{8}$	PF2461-2 $\frac{5}{8}$ TG	26022**	B

*1st Wheel Gray Polyflex, **2nd Wheel Tan Polyflex

Standard Line Conveyor Casters

Load Capacity 270-375 Lbs. Each Caster



The standard-line conveyor casters share some of the same features as the other two lines. The primary difference is a double ball bearing raceway compared to the sealed precision bearing swivel. Wheel materials available include: Rockite, Polyflex, and Plaskite. Rockite is a hard rubber molded composition throughout; this wheel is impervious to oils and greases, has a high load capacity and good mobility. Polyolefin (Polyflex) wheel is light in weight, low in cost, and high in impact strength. It resists water and chemical absorption and withstands steam cleaning. The Plaskite wheel is a phenolic compound reinforced with macerated fabric that results in a high-strength, high impact wheel resistant to oil, gasoline, even dilute acids.

Wheel Diameter	Tread Width (In.)	Wheel Type	Wheel Bearing	Axle Size (In.)	Load Capacity (Lbs.)	Overall Height (In.)	Swivel Radius (In.)	Mounting Bolt Dia. (In.)	Swivel Caster Desc.	Order No.	Top Plate
3	1 $\frac{1}{8}$	Hard Rubber	Ball	$\frac{5}{16}$	270	3 $\frac{25}{32}$	2 $\frac{5}{8}$	$\frac{3}{8}$	429-3x1 $\frac{1}{8}$ TG	25526	C
	1 $\frac{5}{16}$	Polyflex	Ball	$\frac{5}{16}$	270	3 $\frac{25}{32}$	2 $\frac{5}{8}$	$\frac{3}{8}$	461-3x1 $\frac{5}{16}$ TG	25675	C
		Phenolic	Ball	$\frac{5}{16}$	300	4 $\frac{1}{32}$	2 $\frac{15}{32}$	$\frac{3}{8}$	331-3x1 $\frac{5}{16}$ TG	25278	C
		Polyflex	Ball	$\frac{5}{16}$	300	4 $\frac{1}{32}$	2 $\frac{15}{32}$	$\frac{3}{8}$	H461-3x1 $\frac{5}{16}$ TG	25696	C

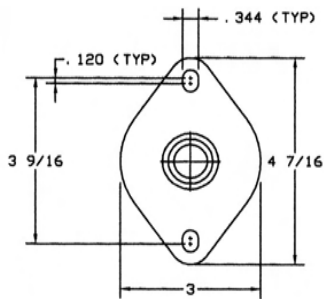

A

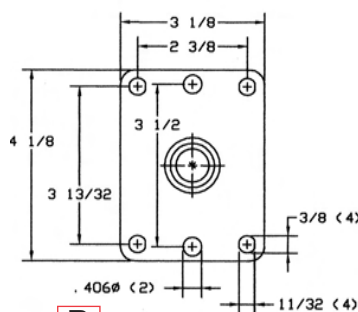

B

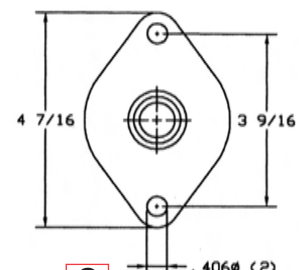

C

LOW PROFILE MEDIUM HEAVY DUTY CASTERS



Business Machine Casters

Load Capacity 200-1,200 Lbs. Each Caster

Made to support and move heavy office equipment where overall height is a limiting factor. Ideal for use on copiers, computers, large printers, and other heavy diagnostic equipment.



HX1435-3x1¹/₁₆



HXEP629R



HA435-3x1¹³/₁₆



335-3x1¹³/₁₆

- **High Load Rating Capacities**
- **Low Overall Height**
- **Excellent Floor and Carpet Protection**
- **Brakes** — Optional thumb screw brake and side brake available on some items. Contact factory for availability.
- **Finishes** — Black oxide with corrosion-resistant zinc top plate or all zinc finish

SPECIALTY CASTERS

Wheel Dia. (In.)	Tread Width (In.)	Wheel Material	Wheel Bearing	Axle Size (In.)	Load Rating (Lbs.)	Overall Height (In.)	Swivel Radius (In.)	Mounting Bolt Dia. (In.)	Bolt Hole Spacing (In.)	Overall Top Plate Size (In.)	Swivel Caster Desc.	Order No.
2	1 ¹³ / ₁₆	Hard Rubber	Roller	5/16	275	2 ²⁷ / ₃₂	2 1/16	5/16	1 3/4 x 2 7/8 to 3	2 9/16 x 3 5/8	EP729-2R**BM	29945
	1 ¹¹ / ₁₆	Polypropylene	Plain	5/16	300	2 ²⁷ / ₃₂	2 1/16	5/16	1 3/4 x 2 7/8 to 3	2 9/16 x 3 5/8	HXEP629R BM	31151
2 5/8	1 1/2	Phenolic	Roller	7/16	240	3 5/16	2 7/16	N/A	1/2-13x1 1/2***	N/A	G431-2 5/8*	25607
2 1/2	1 1/8	Hard Rubber	Plain	5/16	200	3 3/16	2 3/16	5/16	1 3/4 x 3	2 3/4 x 3 7/16	127-2 1/2*	25128
	1 3/4	Polypropylene	Roller	7/16	400	3 1/2	2 1/8	5/16	1 3/4 x 2 7/8 to 3	2 9/16 x 3 5/8	H461-2 1/2R BM	25673
3	1 13/16	Glass Filled Nylon	Roller	7/16	700	4 5/16	2 1/2	3/8	2 5/8 x 3 5/8 to 3x3	3 3/4 x 4 5/8	935-3 x 1 13/16*	26220
		Glass Filled Nylon	Roller	7/16	700	3 31/32	2 1/16	5/16	2 3/8 x 3 3/8	3 1/8 x 4 1/8	335-3 x 1 13/16*	25294
		Glass Filled Nylon	Roller	7/16	1000	3 31/32	2 7/16	5/16	2 3/8 x 3 3/8	3 1/8 x 4 1/8	H335-3 x 1 13/16*	25295
		Glass Filled Nylon	Roller	7/16	700	3 31/32	2 7/16	5/16	2 3/8 x 3 3/8	3 1/8 x 4 1/8	335-3 x 1 13/16 BM	25283
		Glass Filled Nylon	Roller	7/16	1000	3 31/32	2 5/16	5/16	2 3/8 x 3 3/8	3 1/8 x 4 1/8	H335-3 x 1 13/16 BM	25284
		Glass Filled Nylon	Roller	3/8	500	3 31/32	2 5/16	5/16	2 3/8 x 3 13/32	3 1/8 x 4 1/8	HA435-3 x 1 13/16 BM	25330
		Polypropylene	Plain	3/8	550	3 31/32	2 5/16	5/16	2 3/8 x 3 13/32	3 1/8 x 4 1/8	HA360-3x1 13/16 RBM	25300
		Glass Filled Nylon	Roller	1/2	1000	4 5/32	2 3/8	5/16	2 3/8 x 3 3/8	3 5/16 x 4 1/8	HX1435-3x1 13/16*	26341
		Glass Filled Nylon	Roller	1/2	1200	4 5/32	2 3/8	5/16	2 3/8 x 3 3/8	3 5/16 x 4 1/8	HX1435H3x1 13/16 BM	26973

NOTE: Contact factory for rigid options available.
Options: Wheel Face Brake (add WFB Suffix - Ex: 335-3WFB)

*Zinc finish
**Dual wheels

Wheel Options

*** 1/2-13 X 1 1/2 Threaded Stem



Glass Filled Nylon



Polypropylene



Hard Rubber



SHOCK ABSORBING CASTERS

SHX 1400

Load Capacity 350-1600 Lbs. Each Caster



- **Shock Absorbing** — Patented shock absorbing system utilizing pre-torqued elastomers with a weight sensitive pivot mechanism
- **Low Profile** — 3" diameter wheel size
- **Finish** — Corrosion-resistant Black oxide standard finish, corrosion-resistant zinc optional
- **Wheels** — Glass filled nylon with roller bearing standard

The SHX 1400 Series specialty casters are designed to provide added protection when moving sensitive payloads, such as business machines or test equipment.

This SHX series has passed extensive laboratory testing to simulate a wide variety of impacts and vibrations that may occur during transportation.

As shocks occur or loads temporarily exceed capacity, the shock absorbing mechanism activates and protects sensitive loads. This caster line is ideal for heavy loads requiring compact space allotments.

Wheel Dia. (In.)	Tread Width (In.)	Overall Height (In.)	Swivel Offset (In.)	Swivel Radius (In.)	Maximum Load (Lbs.)	Pre-Loaded (Lbs.)	Swivel Caster Desc.	Order No.
3	1 ¹³ / ₁₆	4 ²¹ / ₃₂	1 ³ / ₁₆	2 ⁷ / ₁₆	900 with .350" Total Height Deflection	350	SHX1435-3x1 ¹³ / ₁₆	26328
		4 ²¹ / ₃₂	1 ³ / ₁₆	2 ⁷ / ₁₆	1250 with .250" Total Height Deflection	550	SHX1435-3x1 ¹³ / ₁₆	26329
		4 ²¹ / ₃₂	1 ³ / ₁₆	2 ⁷ / ₁₆	1600 with .250" Total Height Deflection	850	SHX1435-3x1 ¹³ / ₁₆	26334

OPTIONS: Swivel locking system, wheel brakes, variety of load ratings.

NOTE: All SHX Product are produced to custom order. Consult your distributor or factory for availability.

Mounting Bolt Dia. — 5/16"
Axle Size — 1/2"

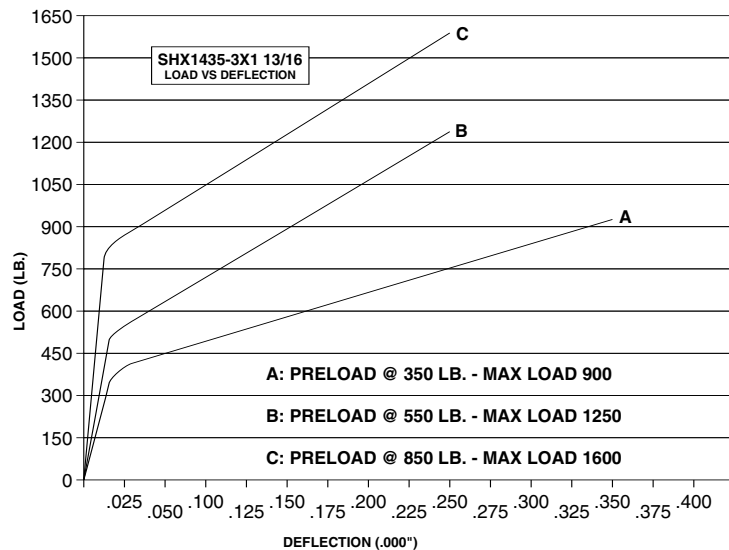
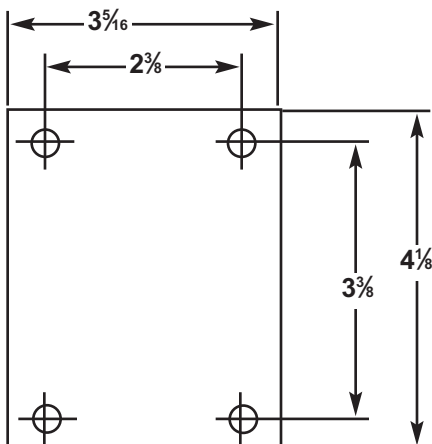

SPECIALTY CASTERS

Shock Absorbing for Sensitive Loads

Load Capacity 900-1,200 Lbs. Each Caster

Industrial Spring Action Casters are used for safe movement of calibrated instruments, delicately adjusted assemblies, tool boxes, and other load sensitive products.



SH1435-6TGBRK

- **Double Action Spring** — Compression action absorbs the jolts and bumps caused by rough floors, thresholds, etc.
- **Spring and Draw Bars** — Durable, long lasting spring and draw bars are on center line of wheel to prevent offset of load
- **2-to-1 Lever Arm** — Helps reduce shock and lengthens spring life
- **Constant Contact** — Wheels contact floor surface at all times, eliminating bounce and keeping unit at a more constant level
- **Thread Guards** — Chrome Finish
- **Finish** — Black Epoxy

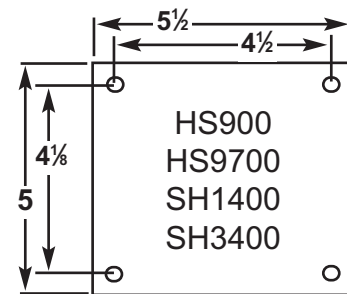

Wheel Dia. (In.) (A)	Tread Width (In.)	Wheel Material	Wheel Bearing	Load Rating (Lbs.)	Overall Height (B) (In.)	Swivel Radius (C) (In.)	Swivel Caster Desc.	Order No.	Rigid Caster Desc.	Order No.
6	2	RT	Roller	900	8 1/2	4 3/32	HS965W-6x2TGBrk	26059	HS9765W-6x2TG	27525
		Glass Filled Nylon	Roller	1200	9 1/16	4 3/32	SH1435-6x2TGBrk	26555	SH3435-6x2TG	26737
8	2	Super K	Precision	1500	10 3/8	6 7/16	SH1441B-8x2Brk	26245	SH3441B-8x2	27368
	2 1/2	Super K	Precision	2000	10 3/8	6 5/8	SH1441B-8x2-1/2Brk	26260	SH3441B-8x2-1/2	27369

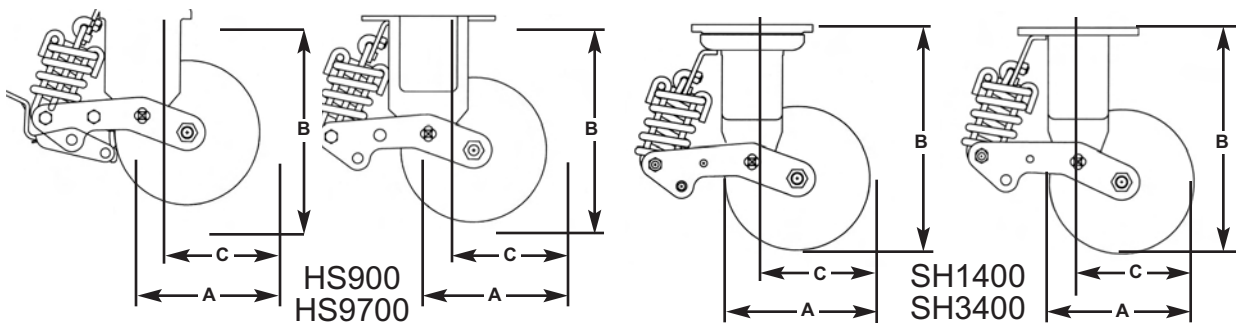

Mounting Bolt Diameter — 3/8"